

ETSI EN 303 661 V1.1.1 (2024-05)



**Short Range Devices (SRD);
Ground Based Synthetic Aperture Radar (GBSAR)
in the frequency range 17,1 GHz to 17,3 GHz and
High Definition Ground Based Synthetic Aperture Radar
(HD-GBSAR) in the frequency range 76 GHz to 77 GHz;
Harmonised Standard for access to radio spectrum**

ReferenceDEN/ERM-TGUWB-591

Keywordsharmonised standard, measurement, radio, SRD

ETSI650 Route des Lucioles
F-06921 Sophia Antipolis Cedex - FRANCE

Tel.: +33 4 92 94 42 00 Fax: +33 4 93 65 47 16

Siret N° 348 623 562 00017 - APE 7112B
Association à but non lucratif enregistrée à la
Sous-Préfecture de Grasse (06) N° w061004871

Important notice

The present document can be downloaded from:

<https://www.etsi.org/standards-search>

The present document may be made available in electronic versions and/or in print. The content of any electronic and/or print versions of the present document shall not be modified without the prior written authorization of ETSI. In case of any existing or perceived difference in contents between such versions and/or in print, the prevailing version of an ETSI deliverable is the one made publicly available in PDF format at www.etsi.org/deliver.

Users of the present document should be aware that the document may be subject to revision or change of status.

Information on the current status of this and other ETSI documents is available at

<https://portal.etsi.org/TB/ETSIDeliverableStatus.aspx>

If you find errors in the present document, please send your comment to one of the following services:

<https://portal.etsi.org/People/CommitteeSupportStaff.aspx>

If you find a security vulnerability in the present document, please report it through our
Coordinated Vulnerability Disclosure Program:

<https://www.etsi.org/standards/coordinated-vulnerability-disclosure>

Notice of disclaimer & limitation of liability

The information provided in the present deliverable is directed solely to professionals who have the appropriate degree of experience to understand and interpret its content in accordance with generally accepted engineering or other professional standard and applicable regulations.

No recommendation as to products and services or vendors is made or should be implied.

In no event shall ETSI be held liable for loss of profits or any other incidental or consequential damages.

Any software contained in this deliverable is provided "AS IS" with no warranties, express or implied, including but not limited to, the warranties of merchantability, fitness for a particular purpose and non-infringement of intellectual property rights and ETSI shall not be held liable in any event for any damages whatsoever (including, without limitation, damages for loss of profits, business interruption, loss of information, or any other pecuniary loss) arising out of or related to the use of or inability to use the software.

Copyright Notification

No part may be reproduced or utilized in any form or by any means, electronic or mechanical, including photocopying and microfilm except as authorized by written permission of ETSI.

The content of the PDF version shall not be modified without the written authorization of ETSI.

The copyright and the foregoing restriction extend to reproduction in all media.

© ETSI 2024.
All rights reserved.

Contents

| | |
|---|----|
| Intellectual Property Rights | 6 |
| Foreword..... | 6 |
| Modal verbs terminology..... | 7 |
| Introduction | 7 |
| 1 Scope | 8 |
| 2 References | 8 |
| 2.1 Normative references | 8 |
| 2.2 Informative references..... | 8 |
| 3 Definition of terms, symbols and abbreviations..... | 9 |
| 3.1 Terms..... | 9 |
| 3.2 Symbols..... | 10 |
| 3.3 Abbreviations | 10 |
| 4 Technical requirements specifications | 11 |
| 4.1 Environmental profile..... | 11 |
| 4.2 EUT categories..... | 11 |
| 4.3 Transmitter conformance requirements..... | 12 |
| 4.3.1 Operating Frequency Range (OFR) | 12 |
| 4.3.1.1 Applicability..... | 12 |
| 4.3.1.2 Description | 12 |
| 4.3.1.3 Limits | 12 |
| 4.3.1.4 Conformance..... | 13 |
| 4.3.2 Mean e.i.r.p. | 13 |
| 4.3.2.1 Applicability..... | 13 |
| 4.3.2.2 Description | 13 |
| 4.3.2.3 Limits | 13 |
| 4.3.2.4 Conformance..... | 13 |
| 4.3.3 Mean e.i.r.p. spectral density | 13 |
| 4.3.3.1 Applicability..... | 13 |
| 4.3.3.2 Description | 13 |
| 4.3.3.3 Limits | 13 |
| 4.3.3.4 Conformance..... | 13 |
| 4.3.4 TX unwanted emissions..... | 14 |
| 4.3.4.1 Applicability..... | 14 |
| 4.3.4.2 Description | 14 |
| 4.3.4.3 Limits | 14 |
| 4.3.4.4 Conformance..... | 16 |
| 4.3.5 TX behaviour under the complete environmental profile | 16 |
| 4.3.5.1 Applicability..... | 16 |
| 4.3.5.2 Description | 16 |
| 4.3.5.3 Limits | 16 |
| 4.3.5.4 Conformance..... | 16 |
| 4.4 Receiver conformance requirements | 16 |
| 4.4.1 General..... | 16 |
| 4.4.2 Receiver spurious emissions | 17 |
| 4.4.2.1 Applicability..... | 17 |
| 4.4.2.2 Description | 17 |
| 4.4.2.3 Limits | 17 |
| 4.4.2.4 Conformance..... | 17 |
| 4.4.3 Wanted Technical Performance Criterion (WTPC)..... | 17 |
| 4.4.4 Receiver Baseline Sensitivity (RBS) | 17 |
| 4.4.4.1 Applicability..... | 17 |
| 4.4.4.2 Description | 17 |
| 4.4.4.3 Limits | 17 |
| 4.4.4.4 Conformance..... | 17 |

| | | |
|-----------|---|----|
| 4.4.5 | Receiver Baseline Resilience (RBR) | 18 |
| 4.4.5.1 | Applicability | 18 |
| 4.4.5.2 | Description | 18 |
| 4.4.5.3 | Limits | 18 |
| 4.4.5.4 | Conformance | 18 |
| 4.5 | Requirements for spectrum access | 18 |
| 4.5.1 | DAA for GBSAR | 18 |
| 4.5.1.1 | Applicability | 18 |
| 4.5.1.2 | Description | 18 |
| 4.5.1.3 | Limit | 19 |
| 4.5.1.4 | Conformance | 20 |
| 4.5.2 | DAA for HD-GBSAR | 20 |
| 4.5.2.1 | Applicability | 20 |
| 4.5.2.2 | Description | 20 |
| 4.5.2.3 | Limit | 20 |
| 4.5.2.4 | Conformance | 21 |
| 4.6 | Requirements for antenna | 21 |
| 4.6.1 | Antenna pattern | 21 |
| 4.6.1.1 | Applicability | 21 |
| 4.6.1.2 | Description | 21 |
| 4.6.1.3 | Limit | 22 |
| 4.6.1.4 | Conformance | 23 |
| 5 | Testing for compliance with technical requirements | 23 |
| 5.1 | Environmental conditions for testing | 23 |
| 5.1.1 | General | 23 |
| 5.1.2 | Normal test conditions | 23 |
| 5.1.3 | Complete environmental profile test conditions | 24 |
| 5.2 | General conditions for testing | 24 |
| 5.3 | Conformance test suites | 24 |
| 5.4 | Conformance methods of measurement for transmitter | 24 |
| 5.4.1 | General | 24 |
| 5.4.2 | Operating Frequency Range | 24 |
| 5.4.3 | Mean e.i.r.p. | 24 |
| 5.4.4 | Mean e.i.r.p. Spectral Density | 25 |
| 5.4.5 | TX unwanted emissions | 25 |
| 5.4.6 | TX behaviour under the complete environmental profile | 25 |
| 5.4.6.1 | EUT with a 50 Ω transmitter output connector | 25 |
| 5.4.6.2 | EUT with integral or dedicated antenna | 25 |
| 5.4.6.3 | Procedure for tests at extreme conditions | 25 |
| 5.4.6.3.1 | General | 25 |
| 5.4.6.3.2 | Conducted test procedure for EUT provided with a 50 Ω transmitter output connector | 26 |
| 5.4.6.3.3 | Radiated test procedure for EUT with integral or dedicated antenna | 26 |
| 5.5 | Conformance methods of measurement for receiver | 27 |
| 5.5.1 | General | 27 |
| 5.5.2 | Receiver spurious emissions | 27 |
| 5.5.3 | Receiver Baseline Sensitivity (RBS) | 27 |
| 5.5.4 | Receiver Baseline Resilience (RBR) | 28 |
| 5.6 | Conformance methods of measurement for spectrum access | 28 |
| 5.6.1 | General | 28 |
| 5.6.2 | DAA for GBSAR | 28 |
| 5.6.2.1 | General | 28 |
| 5.6.2.2 | Test procedure | 29 |
| 5.6.2.2.1 | General | 29 |
| 5.6.2.2.2 | Test signal | 29 |
| 5.6.2.2.3 | DAA Threshold | 29 |
| 5.6.2.2.4 | Minimum Listen Time | 29 |
| 5.6.2.2.5 | Minimum Listen Time after detection | 30 |
| 5.6.2.2.6 | Maximum transmitter switch-off time | 31 |
| 5.6.3 | DAA for HD-GBSAR | 32 |
| 5.6.3.1 | General | 32 |
| 5.6.3.2 | Test procedure | 33 |

| | | |
|-------------------------------|--|-----------|
| 5.6.3.2.1 | General | 33 |
| 5.6.3.2.2 | Test signal..... | 33 |
| 5.6.3.2.3 | DAA Threshold and Timing | 33 |
| 5.7 | Conformance methods of measurement for antenna | 33 |
| 5.7.1 | General..... | 33 |
| 5.7.2 | Measuring distance | 34 |
| 5.7.2.1 | General | 34 |
| 5.7.2.2 | Standard position..... | 34 |
| 5.7.2.3 | Auxiliary cables | 34 |
| 5.7.3 | Test procedure | 35 |
| Annex A (informative): | Relationship between the present document and the essential requirements of Directive 2014/53/EU | 36 |
| Annex B (informative): | General conditions for testing, measurement uncertainty and interpretation of the measurement results | 38 |
| Annex C (normative): | Use-Case, wanted technical performance criterion and RX-test conditions..... | 39 |
| C.1 | Description | 39 |
| C.2 | Wanted Technical Performance Criterion (WTPC) and RX - requirement | 39 |
| C.2.1 | General | 39 |
| C.2.2 | RBS-requirement and limit..... | 40 |
| C.2.3 | RBR requirement and limit | 40 |
| Annex D (normative): | Interferer for RBR test..... | 41 |
| D.1 | Interferer requirements for RBR tests | 41 |
| D.1.1 | General test frequencies for RBR tests..... | 41 |
| D.1.2 | Test frequencies for GBSAR..... | 41 |
| D.1.3 | Test frequencies for HD-GBSAR..... | 42 |
| Annex E (informative): | Test signals for the HD-GBSAR DAA | 43 |
| E.1 | General | 43 |
| E.2 | Interference with automotive radar signals | 43 |
| E.2.1 | Characteristics of automotive radar signals..... | 43 |
| E.2.2 | Interference between two FMCW signals | 44 |
| E.2.3 | Selection of the test signals for the HD-GBSAR DAA..... | 45 |
| Annex F (informative): | Mapping requirements..... | 47 |
| Annex G (informative): | Bibliography..... | 49 |
| Annex H (informative): | Change history | 50 |
| History | | 51 |

Intellectual Property Rights

Essential patents

IPRs essential or potentially essential to normative deliverables may have been declared to ETSI. The declarations pertaining to these essential IPRs, if any, are publicly available for **ETSI members and non-members**, and can be found in ETSI SR 000 314: "*Intellectual Property Rights (IPRs); Essential, or potentially Essential, IPRs notified to ETSI in respect of ETSI standards*", which is available from the ETSI Secretariat. Latest updates are available on the ETSI Web server (<https://ipr.etsi.org/>).

Pursuant to the ETSI Directives including the ETSI IPR Policy, no investigation regarding the essentiality of IPRs, including IPR searches, has been carried out by ETSI. No guarantee can be given as to the existence of other IPRs not referenced in ETSI SR 000 314 (or the updates on the ETSI Web server) which are, or may be, or may become, essential to the present document.

Trademarks

The present document may include trademarks and/or tradenames which are asserted and/or registered by their owners. ETSI claims no ownership of these except for any which are indicated as being the property of ETSI, and conveys no right to use or reproduce any trademark and/or tradename. Mention of those trademarks in the present document does not constitute an endorsement by ETSI of products, services or organizations associated with those trademarks.

DECT™, **PLUGTESTS™**, **UMTS™** and the ETSI logo are trademarks of ETSI registered for the benefit of its Members. **3GPP™** and **LTE™** are trademarks of ETSI registered for the benefit of its Members and of the 3GPP Organizational Partners. **oneM2M™** logo is a trademark of ETSI registered for the benefit of its Members and of the oneM2M Partners. **GSM®** and the GSM logo are trademarks registered and owned by the GSM Association.

Foreword

This Harmonised European Standard (EN) has been produced by ETSI Technical Committee Electromagnetic compatibility and Radio spectrum Matters (ERM).

The present document has been prepared under the Commission's standardisation request C(2015) 5376 final [i.6] to provide one voluntary means of conforming to the essential requirements of Directive 2014/53/EU on the harmonisation of the laws of the Member States relating to the making available on the market of radio equipment and repealing Directive 1999/5/EC [i.1].

Once the present document is cited in the Official Journal of the European Union under that Directive, compliance with the normative clauses of the present document given in table A.1 confers, within the limits of the scope of the present document, a presumption of conformity with the corresponding essential requirements of that Directive and associated EFTA regulations.

| National transposition dates | |
|--|------------------|
| Date of adoption of this EN: | 20 May 2024 |
| Date of latest announcement of this EN (doa): | 31 August 2024 |
| Date of latest publication of new National Standard or endorsement of this EN (dop/e): | 28 February 2025 |
| Date of withdrawal of any conflicting National Standard (dow): | 28 February 2026 |

Modal verbs terminology

In the present document "**shall**", "**shall not**", "**should**", "**should not**", "**may**", "**need not**", "**will**", "**will not**", "**can**" and "**cannot**" are to be interpreted as described in clause 3.2 of the [ETSI Drafting Rules](#) (Verbal forms for the expression of provisions).

"**must**" and "**must not**" are **NOT** allowed in ETSI deliverables except when used in direct citation.

Introduction

The present document is developed by ETSI and is designed to fit in a modular structure to cover all radio and telecommunications terminal equipment within the scope of the Directive 2014/53/EU [i.1].

It specifically aims at providing requirements for Ground Based Synthetic Aperture Radar (GBSAR) and High Definition Ground Based Synthetic Aperture Radar (HD-GBSAR). GBSAR and HD-GBSAR are Short Range Devices used for radiodetermination application. The GBSAR and HD-GBSAR applications are intended exclusively for detection of movement related to structures potentially effecting the protection of workers and the general public.

1 Scope

The present document specifies technical characteristics and methods of measurements for Ground Based Synthetic Aperture Radar (GBSAR) in the frequency range 17,1 GHz to 17,3 GHz and High Definition Ground Based Synthetic Aperture Radar (HD-GBSAR) in the frequency range 76 GHz to 77 GHz.

NOTE: The relationship between the present document and essential requirements of article 3.2 of Directive 2014/53/EU [i.1] is given in annex A.

2 References

2.1 Normative references

References are either specific (identified by date of publication and/or edition number or version number) or non-specific. For specific references, only the cited version applies. For non-specific references, the latest version of the referenced document (including any amendments) applies.

Referenced documents which are not found to be publicly available in the expected location might be found at <https://docbox.etsi.org/Reference/>.

NOTE: While any hyperlinks included in this clause were valid at the time of publication, ETSI cannot guarantee their long term validity.

The following referenced documents are necessary for the application of the present document.

- [1] [ETSI EN 303 883-1 \(V1.2.1\) \(02-2021\)](#): "Short Range Devices (SRD) and Ultra Wide Band (UWB); Part 1: Measurement techniques for transmitter requirements".
- [2] [ETSI EN 303 883-2 \(V1.2.1\) \(02-2021\)](#): "Short Range Devices (SRD) and Ultra Wide Band (UWB); Part 2: Measurement techniques for receiver requirements".

2.2 Informative references

References are either specific (identified by date of publication and/or edition number or version number) or non-specific. For specific references, only the cited version applies. For non-specific references, the latest version of the referenced document (including any amendments) applies.

NOTE: While any hyperlinks included in this clause were valid at the time of publication, ETSI cannot guarantee their long term validity.

The following referenced documents are not necessary for the application of the present document but they assist the user with regard to a particular subject area.

- [i.1] [Directive 2014/53/EU](#) of the European Parliament and of the Council of 16 April 2014 on the harmonisation of the laws of the Member States relating to the making available on the market of radio equipment and repealing Directive 1999/5/EC (RE-Directive).
- [i.2] [CEPT/ERC Recommendation 70-03](#): "Relating to the use of Short Range Devices (SRD)".
- [i.3] [Commission Implementing Decision \(EU\) 2022/180 of 8 February 2022](#) amending Decision 2006/771/EC as regards the update of harmonised technical conditions in the area of radio spectrum use for short-range devices (notified under document C(2022) 644).
- [i.4] ETSI TS 103 361 (V1.1.1): "Short Range Devices (SRD) using Ultra Wide Band technology (UWB); Receiver technical requirements, parameters and measurement procedures to fulfil the requirements of the Directive 2014/53/EU".
- [i.5] [CEPT/ERC/Recommendation 74-01](#): "Unwanted emissions in the spurious domain".

- [i.6] [Commission implementing Decision C\(2015\) 5376 final of 4.8.2015](#) on a standardisation request to the European Committee for Electrotechnical Standardisation and to the European Telecommunications Standards Institute as regards radio equipment in support of Directive 2014/53/EU of the European Parliament and of the Council.
- [i.7] [ECC Report 111](#): "Compatibility studies between Ground Based Synthetic Aperture Radar (GBSAR) and existing services in the range 17.1 GHz to 17.3 GHz".
- [i.8] [ECC Report 315](#): "Feasibility of spectrum sharing between High-Definition Ground Based Synthetic Aperture Radar (HD-GBSAR) application using 1 GHz bandwidth within 74-81 GHz and existing services and applications".
- [i.9] [ECC/DEC/\(21\)02](#): "The harmonised frequency band 76-77 GHz, technical characteristics, exemption from individual licensing and free circulation and use of High Definition Ground Based Synthetic Aperture Radar (HD-GBSAR)".
- [i.10] [ECC Report 262](#): "Studies related to surveillance radar equipment operating in the 76 to 77 GHz range for fixed transport infrastructure".
- [i.11] [European Communications Office](#): "EFIS: ECO Frequency Information System".
- [i.12] ETSI EG 203 336 (V1.2.1): "Guide for the selection of technical parameters for the production of Harmonised Standards covering article 3.1(b) and article 3.2 of Directive 2014/53/EU".
- [i.13] ETSI TS 103 567 (V1.1.1): "Requirements on signal interferer handling".

3 Definition of terms, symbols and abbreviations

3.1 Terms

For the purposes of the present document, the terms given in ETSI EN 303 883-1 [1], ETSI EN 303 883-2 [2] and the following apply:

conducted measurements: measurements which are made using a wired/wave-guided connection to the equipment under test

dedicated antenna: antenna specifically designed for being attached to the radio equipment (i.e. with special mechanical fixing to the antenna port of the specific radio supplied), but can be separated from the equipment (typically for transport purpose) by using normal tools

NOTE: Normal tools are mechanical tools like open-end wrenches or screw drivers.

Ground Based Synthetic Aperture Radar (GBSAR): radiodetermination application for the detection of movement related to structures potentially affecting the protection of workers and the general public

integral antenna: antenna designed to be connected to the equipment without the use of an external connector and considered to be part of the equipment

NOTE: An integral antenna may be fitted internally or externally to the equipment.

radiodetermination: determination of the position, velocity and/or other characteristics of an object, or the obtaining of information relating to these parameters, by means of the propagation properties of radio waves

receiver spurious emissions: receiver unwanted emissions that emanate from the EUT. Receiver spurious emissions are generated internally by the receiver or result from the interaction of the RX coupling with the TX signal

smart antenna systems: equipment that combines multiple transmit and/or receive chains with a signal processing function to increase the throughput and/or to optimize its radiation and/or reception capabilities

NOTE: These are techniques such as spatial multiplexing, beamforming, cyclic delay diversity, MIMO, etc.

3.2 Symbols

For the purposes of the present document, the symbols given in ETSI EN 303 883-1 [1], ETSI EN 303 883-2 [2] and the following apply:

| | |
|------------------|---|
| B | Bandwidth automotive radar |
| D | output logic signal |
| dBsm | decibels per square meter |
| f_{LP} | lower edge of the permitted frequency range |
| f_{HP} | upper edge of the permitted frequency range |
| m | meter |
| mm | millimeter |
| ms | millisecond |
| M | Margin of the measured maximum mean e.i.r.p. to the limit of table 4 |
| MEP | Maximum mean e.i.r.p. measured across the EUT environmental profile |
| P_{DAA} | Peak power DAA threshold |
| P_{max} | measured mean e.i.r.p. as measured and corrected by the EUT OFR |
| PSD_{MAX} | measured maximum mean e.i.r.p. spectral density within the EUT OFR |
| P_I | HD-GBSAR conducted peak power at the transmitter antenna input in dBm |
| P_V | power value of HD-GBSAR DAA test signal |
| P_V^* | power value +10 dB above the value P_V |
| R | Reference value for the Maximum mean e.i.r.p. |
| $r(t)$ | measurement distance for RBS and RBR test |
| σ_r | GBSAR/HD-GBSAR accuracy in measuring the displacement |
| σ_φ | GBSAR/HD-GBSAR accuracy in measuring phase differences |
| S | output logic test signal |
| t_0 | time at which GBSAR transmission is intentionally activated |
| t_D | minimum listen time |
| t_e | time at which GBSAR actual transmission is automatically interrupted by the DAA |
| t_L | minimum listen time after detection |
| t_{off} | GBSAR transmitter switch-off time |
| t_S | time at which the GBSAR DAA level falls below the DAA threshold |
| t_t | time at which GBSAR actual transmission is automatically switched-on |

3.3 Abbreviations

For the purposes of the present document, the abbreviations given in ETSI EN 303 883-1 [1], ETSI EN 303 883-2 [2] and the following apply:

| | |
|-------------|---|
| CH | CHannel |
| EDM | Error in Distance Measurement |
| EDM_{max} | maximum Error in Distance Measurement |
| EL | Emission Limit |
| GBSAR | Ground Based Synthetic Aperture Radar |
| HD-GBSAR | High Definition Ground Based Synthetic Aperture Radar |
| LFMCW | Linear Frequency Modulated Continuous Wave |
| NLOS | Non Line-Of-Sight |
| PRR | Pulse Repetition Rate |
| RDD | Radio Determination Device |
| WTPC | Wanted Technical Performance Criterion |

4 Technical requirements specifications

4.1 Environmental profile

The technical requirements of the present document apply under the environmental profile for operation of the equipment, which shall be in accordance with its intended use, but as a minimum, shall be that specified in the test conditions contained in the present document. The equipment shall comply with all the technical requirements of the present document at all times when operating within the boundary limits of the operational environmental profile defined by its intended use.

4.2 EUT categories

The present document covers GBSAR and HD-GBSAR devices.

GBSAR devices are covered by SRD regulations:

- ERC/REC 70-03 [i.2], annex 6 (17,1 GHz to 17,3 GHz); and
- Commission Implementing Decision (EU) 2022/180 [i.3] for SRD, band no. 65.

GBSAR therefore shall provide:

- an output logic test signal indicating when the intended operation command of GBSAR is started and stopped respectively;
- an output logic signal indicating when the DAA is active/not active.

GBSAR devices shall either:

- have a common antenna for both receive and transmit;
- or use same antenna type is used for both receive and transmit with both antennas pointing in the same direction.

HD-GBSAR devices of the present document are covered by ECC Decision:

- ECC/DEC/(21)02 [i.9].

HD-GBSAR therefore shall provide:

- an output logic signal indicating when the DAA is active/not active.

HD-GBSAR devices shall either:

- have a common antenna for both receive and transmit;
- or use same antenna type is used for both receive and transmit with both antennas pointing in the same direction.

An overview of requirements for GBSAR and HD-GBSAR is given in table 1.

Table 1: Overview of requirements for GBSAR and HD-GBSAR covered by ERC/REC 70-03 [i.2], 2022/180/EU [i.3] and ECC/DEC/(21)02 [i.9]

| EUT-category | TX-requirements | | | | RX-requirements | |
|--------------|---|----------------|-------------------|--------|-----------------|---------------|
| | Emission requirements | | Active mitigation | | | |
| | | clause | | clause | | clause |
| GBSAR | OFR | 4.3.1 | DAA | 4.5.1 | WTPC | C.2.1 |
| | Mean e.i.r.p. | 4.3.2 | | | RBS | 4.4.4 & C.2.2 |
| | Mean e.i.r.p. spectral density | Not applicable | | | RBR | 4.4.5 & C.2.3 |
| | TX unwanted emissions | 4.3.4 | | | | |
| | TX behaviour under complete environmental profile | 4.3.5 | | | | |
| HD-GBSAR | OFR | 4.3.1 | DAA | 4.5.2 | WTPC | C.2.1 |
| | Mean e.i.r.p. | 4.3.2 | | | RBS | 4.4.4 & C.2.2 |
| | Mean e.i.r.p. spectral density | 4.3.3 | | | RBR | 4.4.5 & C.2.3 |
| | TX unwanted emissions | 4.3.4 | | | | |
| | TX behaviour under complete environmental profile | 4.3.5 | | | | |

4.3 Transmitter conformance requirements

4.3.1 Operating Frequency Range (OFR)

4.3.1.1 Applicability

This requirement shall apply to all EUT.

4.3.1.2 Description

The description of the Operating Frequency Range is given in clause 5.2 of ETSI EN 303 883-1 [1]. As requested in clause 5.2 of ETSI EN 303 883-1 [1], for all the EUT the value of X is specified to 23 dB.

4.3.1.3 Limits

The OFR of all the EUT shall lie within the permitted frequency range of the EUT (see table 2 for GBSAR and table 3 for HD-GBSAR).

GBSAR equipment within scope of the present document are capable of operating in all or part of the frequency bands given in table 2 with either a Radio Frequency (RF) output connection and dedicated antenna or an integral antenna with a Frequency Modulated Continuous Wave signal.

Table 2: GBSAR permitted frequency range covered by 2022/180/EU [i.3]

| | Frequency Band | Application |
|----------------------------|----------------------|--------------------|
| GBSAR Transmit and Receive | 17,1 GHz to 17,3 GHz | Radiodetermination |

HD-GBSAR equipment within scope of the present document are capable of operating in all or part of the frequency bands given in table 3 with either a Radio Frequency (RF) output connection and dedicated antenna or an integral antenna with a Frequency Modulated Continuous Wave signal.

Table 3: HD-GBSAR permitted frequency range according to ECC/DEC/(21)02 [i.9]

| | Frequency Band | Application |
|-------------------------------|------------------|--------------------|
| HD-GBSAR Transmit and Receive | 76 GHz to 77 GHz | Radiodetermination |

The OFR of all the EUT shall lie within the permitted frequency range of the device (see table 2 for GBSAR and table 3 for HD-GBSAR).

4.3.1.4 Conformance

The conformance test shall be done under normal conditions as defined in clause 5.1.2, the conformance test suite for OFR shall be as defined in clause 5.4.2.

4.3.2 Mean e.i.r.p.

4.3.2.1 Applicability

This requirement shall apply to all EUT.

4.3.2.2 Description

The description of mean e.i.r.p. is given in clause 5.3.1.1 of ETSI EN 303 883-1 [1].

4.3.2.3 Limits

The transmitter mean e.i.r.p. shall not exceed the values given in table 4.

Table 4: Mean e.i.r.p.

| EUT category | Frequency Bands | Power | Notes |
|--------------|----------------------|-----------------|--------------------------|
| GBSAR | 17,1 GHz to 17,3 GHz | 400 mW (26 dBm) | See ERC/REC 70-03 [i.2] |
| HD-GBSAR | 76 GHz to 77 GHz | 63,1 W (48 dBm) | See ECC/DEC/(21)02 [i.9] |

4.3.2.4 Conformance

The conformance test shall be done under normal conditions as defined in clause 5.1.2, the mean e.i.r.p. shall be measured as described in clause 5.4.3 and not exceed the limits in clause 4.3.2.3.

4.3.3 Mean e.i.r.p. spectral density

4.3.3.1 Applicability

This requirement shall apply to all HD-GBSAR EUT.

4.3.3.2 Description

The description of mean e.i.r.p. spectral density is given in clause 5.3.2.1 of ETSI EN 303 883-1 [1].

4.3.3.3 Limits

The transmitter mean e.i.r.p. spectral density shall not exceed the values given in table 5.

Table 5: Maximum mean e.i.r.p. spectral density according to ECC/DEC/(21)02 [i.9]

| Frequency Bands | Limit | Notes |
|------------------|------------|--------------------------|
| 76 GHz to 77 GHz | 18 dBm/MHz | See ECC/DEC/(21)02 [i.9] |

4.3.3.4 Conformance

The conformance test shall be done under normal conditions as defined in clause 5.1.2, the mean e.i.r.p. spectral density shall be measured as described in clause 5.4.4 and not exceed the limits in clause 4.3.3.3.

4.3.4 TX unwanted emissions

4.3.4.1 Applicability

This requirement shall apply to all EUT.

4.3.4.2 Description

The description of TX unwanted emissions is given in clause 5.5.1 of ETSI EN 303 883-1 [1].

4.3.4.3 Limits

Lower and upper frequency for the TX unwanted emissions test are as defined in clause 5.5.1 of ETSI EN 303 883-1 [1]. Based on the description in clause 4.3.4.2 this would lead to the following TX unwanted emissions in the OOB and Spurious Domain, for GBSAR EUT, see figure 1 and HD-GBSAR, see figure 2.

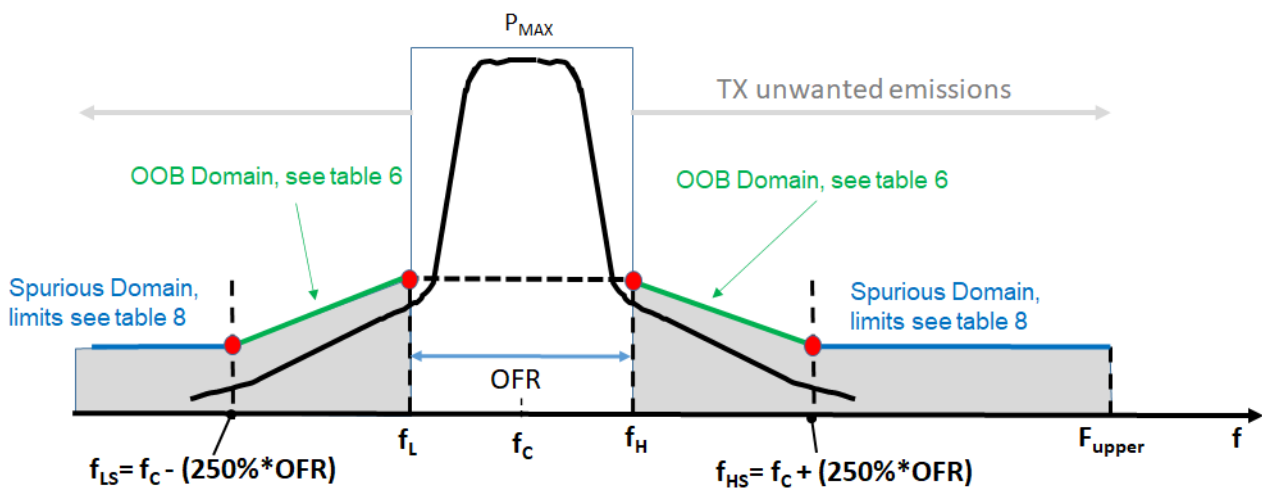

Figure 1: TX unwanted emissions within the OOB and Spurious Domain for GBSAR EUT

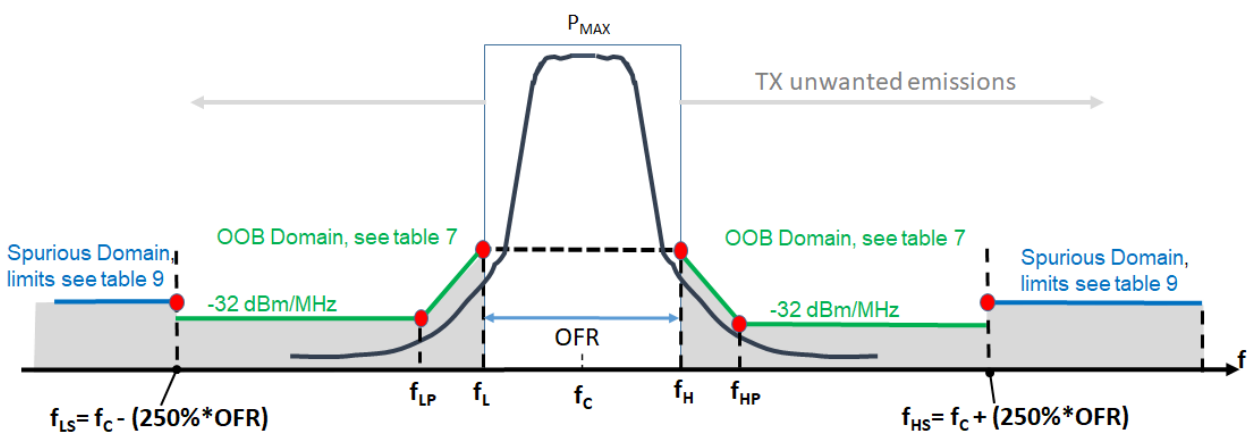

Figure 2: TX unwanted emissions within the OOB and Spurious Domain for HD-GBSAR EUT

The limits below (see table 6) shall apply to the power of any GBSAR emission in the OOB domain.

Table 6: GBSAR emission mask in the OOB domain

| Frequency range | Emission limits (EL) [dBm] (note 1) | Measurement bandwidth |
|--------------------------------|--|-----------------------|
| $f_{LS} \leq f < f_L$ (note 2) | $EL = \left(\frac{P_{MAX} + 10}{f_L - f_{LS}} \right) \times (f - f_{LS}) - 30$ | 1 MHz |
| f_L | $P_{MAX} - 20$ | 1 MHz |
| f_H | $P_{MAX} - 20$ | 1 MHz |
| $f_H < f \leq f_{HS}$ (note 2) | $EL = \left(\frac{P_{MAX} + 10}{f_{HS} - f_H} \right) \times (f_{HS} - f) - 30$ | 1 MHz |

NOTE 1: P_{MAX} (dBm) is the maximum mean e.i.r.p. as measured in clause 4.3.2.
NOTE 2: f_L/f_H are the lowest/highest frequency of the operating frequency range as measured in clause 4.3.1.

The limits below (see table 7) shall apply to the power of any HD-GBSAR emission in the OOB domain.

Table 7: HD-GBSAR emission mask in the OOB domain according to ECC/DEC/(21)02 [i.9]

| Frequency range (note 2, note 3) | Emission limits (EL) [dBm] (note 1) | Measurement bandwidth |
|----------------------------------|--|-----------------------|
| $f_{LS} \leq f < f_{LP}$ | -32 (note 4) | 1 MHz |
| $f_{LP} \leq f < f_L$ | $EL = \left(\frac{P_{MAX} + 12}{f_L - f_{LP}} \right) \times (f - f_{LP}) - 32$ (note 1, note 2) | 1 MHz |
| f_L | $P_{MAX} - 20$ | 1 MHz |
| f_H | $P_{MAX} - 20$ | 1 MHz |
| $f_H < f \leq f_{HP}$ | $EL = \left(\frac{P_{MAX} + 12}{f_{HP} - f_H} \right) \times (f_{HP} - f) - 32$ | 1 MHz |
| $f_{HP} \leq f < f_{HS}$ | -32 (note 4) | 1 MHz |

NOTE 1: P_{MAX} (dBm) is the maximum mean e.i.r.p. as measured in clause 4.3.2.
NOTE 2: f_L/f_H are the lowest/highest frequency of the operating frequency range as measured in clause 4.3.1.
NOTE 3: f_{LP}/f_{HP} are the lower/upper edge of the permitted frequency range (see table 2).
NOTE 4: ECC/DEC/(21)02 [i.9] specifies -22 dBm in 10 MHz measurement bandwidth for this frequency range, which is equivalent to -32 dBm in 1 MHz measurement bandwidth. This limit extends up to 86 GHz in the Spurious Domain, see table 9.

The maximum power limits of any GBSAR TX unwanted emissions in the spurious domain are given in table 8.

Table 8: GBSAR Spurious TX unwanted emissions in the spurious domain according to ERC/REC 74-01 [i.5]

| Frequency range | Limit values for TXUE | Measurement bandwidth |
|--|-----------------------|-----------------------|
| $87,5 \text{ MHz} \leq f \leq 118 \text{ MHz}$ | -54 dBm | 100 kHz |
| $174 \text{ MHz} \leq f \leq 230 \text{ MHz}$ | -54 dBm | 100 kHz |
| $470 \text{ MHz} \leq f \leq 694 \text{ MHz}$ | -54 dBm | 100 kHz |
| otherwise in band $30 \text{ MHz} \leq f < 1\,000 \text{ MHz}$ | -36 dBm | 100 kHz |
| $1\,000 \text{ MHz} \leq f \leq F_{upper}$ (see table 3 in ETSI EN 303 883-1 [1]) | -30 dBm | 1 MHz |

The maximum power limits of any HD-GBSAR TX unwanted emissions in the spurious domain are given in table 9.

Table 9: HD-GBSAR Spurious TX unwanted emissions in the spurious domain according to ERC/REC 74-01 [i.5] and ECC/DEC/(21)02 [i.9]

| Frequency range | Limit values for TXUE | Measurement bandwidth |
|---|-----------------------|-----------------------|
| $87,5 \text{ MHz} \leq f \leq 118 \text{ MHz}$ | -54 dBm | 100 kHz |
| $174 \text{ MHz} \leq f \leq 230 \text{ MHz}$ | -54 dBm | 100 kHz |
| $470 \text{ MHz} \leq f \leq 694 \text{ MHz}$ | -54 dBm | 100 kHz |
| otherwise in band $30 \text{ MHz} \leq f < 1\,000 \text{ MHz}$ | -36 dBm | 100 kHz |
| $1\,000 \text{ MHz} \leq f < 71 \text{ GHz}$ | -30 dBm | 1 MHz |
| $71 \text{ GHz} \leq f \leq f_{LS}$ | -22 dBm (note) | 10 MHz |
| $f_{HS} \leq f \leq 86 \text{ GHz}$ | -22 dBm (note) | 10 MHz |
| $86 \text{ GHz} < f \leq F_{upper}$ (see table 3 in ETSI EN 303 883-1 [1]) | -30 dBm | 1 MHz |
| NOTE: ECC/DEC/(21)02 specifies -22 dBm in 10 MHz measurement bandwidth for this frequency range, which is equivalent to -32 dBm in 1 MHz measurement bandwidth. | | |

4.3.4.4 Conformance

The conformance test shall be done under normal conditions as defined in clause 5.1.2, the level of unwanted emissions in the spurious domain shall be measured as described in clause 5.4.5 and not exceed the limits in clause 4.3.4.3.

4.3.5 TX behaviour under the complete environmental profile

4.3.5.1 Applicability

This requirement shall apply to all EUT.

4.3.5.2 Description

The TX behaviour is obtained by measuring the maximum mean e.i.r.p. (MEP) across the complete environmental profile for operation of the equipment as specified in clause 5.1.3 and computing the variation with respect to a maximum mean e.i.r.p. reference value R, which is the maximum mean e.i.r.p. measured at normal test condition.

The description of mean e.i.r.p. is given in clause 5.3.1.1 of ETSI EN 303 883-1 [1].

4.3.5.3 Limits

The difference between MEP and R, both expressed in decibels, shall be smaller than the difference M between the mean e.i.r.p. limit in table 4 and the maximum measured value according to clause 4.3.2.4 in the same direction.

4.3.5.4 Conformance

The conformance test shall be done under the complete environmental profile; the parameters MEP and R shall be measured as described in clause 5.4.6 and the value of their difference in decibels not exceed the limits in clause 4.3.5.3.

4.4 Receiver conformance requirements

4.4.1 General

The receiver conformance requirements defined below are specified according to the framework as set out in ETSI EN 303 883-2 [2].

With respect to the specific input parameters for the RBR and RBS tests, GBSAR and HD-GBSAR are non-contact based Radio Determination Device (RDD). As described in clause 5.3.3.2 of ETSI EN 303 883-2 [2], the Wanted Technical Performance Criterion (WTPC) is based on the maximum deviation in the distance measurement of a specific target.

4.4.2 Receiver spurious emissions

4.4.2.1 Applicability

This requirement shall apply to all EUT that are RX only devices or that comprise an RX only mode (TX inactive).

4.4.2.2 Description

The description of receiver spurious emissions is given in clause 5.2.1 of ETSI EN 303 883-2 [2].

4.4.2.3 Limits

Limits for the RX spurious emissions shall be as given in table 1 of clause 5.2.2 of ETSI EN 303 883-2 [2].

Frequency range for the RX spurious emission test are as given in table 2 of clause 5.2.2 of ETSI EN 303 883-2 [2].

4.4.2.4 Conformance

The conformance test shall be done under normal conditions as defined in clause 5.1.2, the spurious radiations measurements shall be performed as described in clause 5.5.2 and not exceed the limits in clause 4.4.2.3.

4.4.3 Wanted Technical Performance Criterion (WTPC)

The performance criterion for GBSAR and HD-GBSAR is defined as Error in Distance Measurement (EDM). It is evaluated over a determined measurement time by checking the variance of the measured distance of an object with a given RCS and at a distance $r(t)$ from the EUT. Limits for EDM are provided in table C.3 for RBS and in table C.4 for RBR.

Annex C provides additional information on the performance criterion.

4.4.4 Receiver Baseline Sensitivity (RBS)

4.4.4.1 Applicability

This requirement shall apply to all EUT.

4.4.4.2 Description

The description of the Receiver Baseline Sensitivity is given in clause 5.4.1 of ETSI EN 303 883-2 [2].

4.4.4.3 Limits

The RBS requirements for GBSAR and HD-GBSAR, object distance, duration of measurement and the kind of object and limits shall be as specified in clause C.2.2, table C.1 (object distance, duration of measurement), table C.2 (kind of object) and table C.3 for RBS (limits).

The evaluated EDM value (as defined in clause C.2.1) shall be lower than the limits EDM_{\max} specified in table C.3.

4.4.4.4 Conformance

The conformance test shall be done under normal conditions as defined in clause 5.1.2, the conformance test shall be as defined in clause 5.5.3 and not exceed the limits in clause 4.4.4.3.

4.4.5 Receiver Baseline Resilience (RBR)

4.4.5.1 Applicability

This requirement shall apply to all EUT.

4.4.5.2 Description

The description of the Receiver Baseline Resilience is given in clause 5.5.1 of ETSI EN 303 883-2 [2].

4.4.5.3 Limits

The RBR requirements for GBSAR and HD-GBSAR and limits shall be as specified in clause C.2.3 and table C.4 (limits). For the object distance, the same object distance and duration of measurement as specified for the RBS test shall be used, see table C.1. For the object, the same object as specified for the RBS test shall be used, see table C.2.

The evaluated EDM value (as defined in clause C.2.1) shall be lower than the limit EDM_{max} specified in table C.4.

The interfering signals are specified in clause D.1.2 for GBSAR and clause D.1.3 for HD-GBSAR.

4.4.5.4 Conformance

The conformance test shall be done under normal conditions as defined in clause 5.1.2, the conformance test shall be as defined in clause 5.5.4 and not exceed the limits in clause 4.4.5.3.

4.5 Requirements for spectrum access

4.5.1 DAA for GBSAR

4.5.1.1 Applicability

This requirement shall apply to all GBSAR EUT.

4.5.1.2 Description

The principle of DAA for GBSAR is that GBSAR shall sense the channel within its Operating Frequency Range (OFR), in order to detect the possible presence of sensitive potential victim services. If a potential victim service is detected, GBSAR shall avoid the transmission until the other system disappears.

DAA for GBSAR is characterized by the following parameters (see ECC Report 111 [i.7]):

- t_D : receiver minimum listen time before the GBSAR transmitter can be switched on, immediately prior to any intended transmission;
- Detect And Avoid (DAA) threshold used for deciding whether a victim service is present within GBSAR OFR;
- t_{off} : appropriate long listen-time after detection of a service to be protected.

The operational flow of the DAA for GBSAR is as follows (see figure 3):

- a) Prior to any GBSAR intended transmission, the GBSAR listens to its OFR for a specified time interval t_D , to determine if one or more victim services are transmitting within range.
- b) If a victim service is detected, the GBSAR senses its OFR for a specified time interval t_L , before starting or continuing any transmission.
- c) If no victim service is detected, the GBSAR starts transmitting while continuously sensing the channel in order to detect the presence of a victim services.

- d) If a victim service is detected, GBSAR stop the transmission within t_{off} , go to step b).

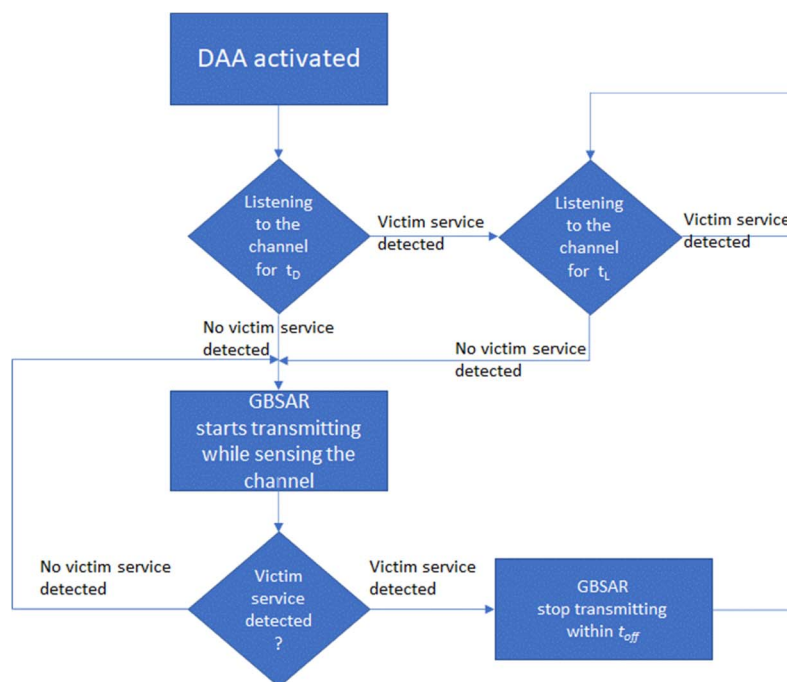

Figure 3: GBSAR Detect and Avoid overview

4.5.1.3 Limit

Characteristics of test signals for the GBSAR are given in table 10.

Table 10: Characteristics of RF test signals for different types of potential victim services for GBSAR according to ECC Report 111 [i.7]

| Parameter | Unit | Type 1 | Type 2 | Type 3 | Type 4 |
|-----------------------------|---------|-----------------|-----------------|-------------------|-----------------|
| Modulation | | Linear FM pulse | Linear FM pulse | Frequency Hopping | Linear FM pulse |
| Frequency range | GHz | 17,1 to 17,3 | 17,1 to 17,2 | 17,1 to 17,3 | 17,1 to 17,3 |
| Chirp bandwidth | MHz | 200 | 100 | 30 | 3 |
| Signal generator | dBm/MHz | -71,0 | -66 | -35,0 | -50,0 |
| Peak Power | dBm | -48,0 | -46 | -20,2 | -45,2 |
| Pulse width | μ s | 15,3 | 40,6 | 0,1 | 17 |
| Pulse Repetition Rate (PRR) | pps | 2 041 | 900 | 1 333 | 3 140 |

The maximum DAA thresholds for each test signal type listed in table 10 shall be as given in table 11.

Table 11: Maximum DAA thresholds according to ECC Report 111 [i.7]

| Test signal type | DAA maximum threshold |
|------------------|-----------------------|
| 1 | -81 dBm/MHz |
| 2 | -76 dBm/MHz |
| 3 | -45 dBm/MHz |
| 4 | -60 dBm/MHz |

GBSAR shall be able to turn off the transmitter either when in listen mode or while transmitting, in case the power density of the test signal at the receiver input overcome the relevant limits specified in table 11.

DAA time parameters limits shall be as given in table 12.

Table 12: DAA Time parameters limit according to ECC Report 111 [i.7]

| Parameter | Description | Limit |
|-----------|-------------------------------------|-------|
| t_D | Minimum listen time | 15 s |
| t_L | Minimum listen time after detection | 120 s |
| t_{off} | Maximum Tx switch-off time | 2 ms |

4.5.1.4 Conformance

The conformance test shall be done under normal conditions as defined in clause 5.1.2, the conformance test suite shall be as defined in clause 5.6.2 and not exceed the limits in clause 4.5.1.3. The values of measured DAA parameters shall be stated in the test report.

4.5.2 DAA for HD-GBSAR

4.5.2.1 Applicability

This requirement shall apply to all HD-GBSAR EUT.

4.5.2.2 Description

The principle of DAA for HD-GBSAR is that HD-GBSAR shall detect the presence of a victim automotive radar in the bandwidth 76 GHz to 77 GHz and stop the transmission within the time of a single automotive radar measurement cycle (50 ms, see table 13).

Characteristics of potential victim automotive radar signals are given in table 13.

Table 13: Characteristics of signals of potential victim automotive radar according to ECC Report 111 [i.7]

| Parameter | Unit | Automotive radar operating in the 76 GHz to 77 GHz frequency band |
|--|---------|---|
| Modulation | | FMCW |
| Frequency range | GHz | 76 to 77 |
| Occupied RF bandwidth | MHz | 100 to 1 000 |
| TX frequency sweep time (slow FMCW) | ms | 1 to 20 |
| TX frequency sweep time (fast FMCW) | μ s | 20 to 80 |
| TX antenna feed power | dBm | 10 |
| TX duty cycle (ratio of transmit on/off) | % | 20 to 50 |
| Radar measurement cycle | ms | 50 |

4.5.2.3 Limit

Characteristics of test signals for the DAA of HD-GBSAR are given in table 14. Annex E provides the justification for the selection of these test signals.

Table 14: Characteristics of RF test signals for the DAA of HD-GBSAR

| Parameter | Unit | Type 1 | Type 2 |
|---|---------|--------|--------|
| Modulation | | FMCW | FMCW |
| Frequency | GHz | 76,5 | 76,5 |
| Occupied RF bandwidth | MHz | 100 | 1 000 |
| Single frequency sweep time (slow FMCW) | ms | --- | 1,3 |
| Single frequency sweep time (fast FMCW) | μ s | 80 | --- |
| Signal repetition time | ms | 50 | 50 |
| Duty cycle | % | 50 | 50 |

The Peak power DAA threshold for the test signal in table 14 is defined by equation (1):

$$\text{Peak Power DAA threshold (dBm)} = P_{DAA} = -70,8 - P_I \quad (1)$$

Where:

- P_I is the HD-GBSAR conducted peak power at the transmitter antenna input in dBm.

The equivalent Average power DAA threshold corresponds to:

$$\text{Average Power DAA threshold (dBm)} = -70,8 - P_I + 10 \times \log_{10} DC \quad (2)$$

Where:

- DC is the test signal duty cycle (TX duty cycle in table 14).

The DAA shall detect the presence of an automotive radar and stop the transmission within the time of a single radar measurement cycle.

4.5.2.4 Conformance

The conformance test shall be done under normal conditions as defined in clause 5.1.2, the conformance test suite shall be as defined in clause 5.6.3. The HD-GBSAR shall stop the transmission within the time of a single radar measurement cycle when the power of the test signal at the input of the HD-GBSAR receiver exceeds the threshold in clause 4.5.2.3.

4.6 Requirements for antenna

4.6.1 Antenna pattern

4.6.1.1 Applicability

This requirement shall apply to all GBSAR EUT.

The antenna pattern requirements shall apply to both dedicated and integral antennas. In case of separate transmitting and receiving antennas, the limit applies only to the transmitting antenna.

In case of device with multiple transmitting antennas, the requirements apply to all the transmitting antennas.

4.6.1.2 Description

The antenna pattern is defined as the antenna radiating efficiency in all directions relative to the antenna boresight.

4.6.1.3 Limit

The EUT antenna pattern measured as defined in clause 4.6.1.2 shall not have less attenuation than the limit curves given in figures 4 and 5 and conveniently recalled in table 15.

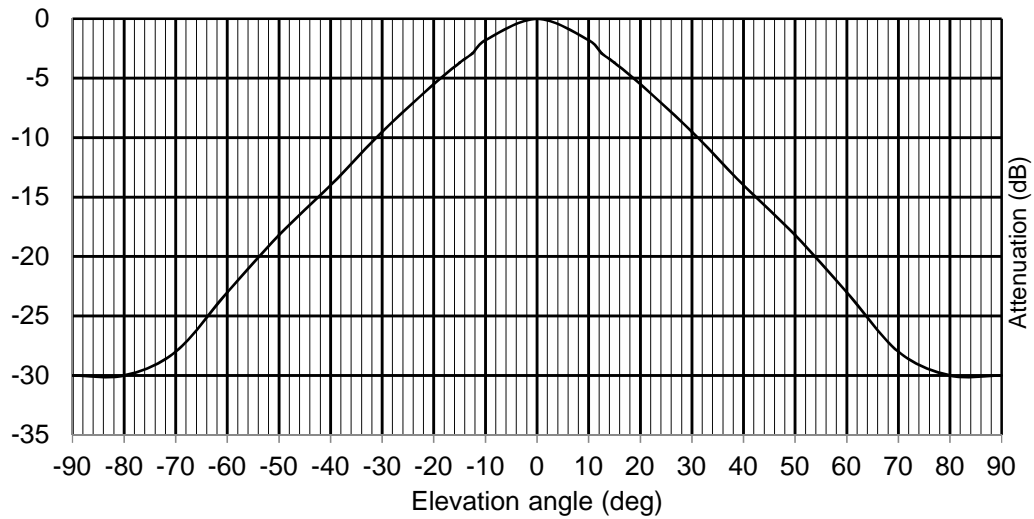

Figure 4: Minimum attenuation of the vertical antenna pattern

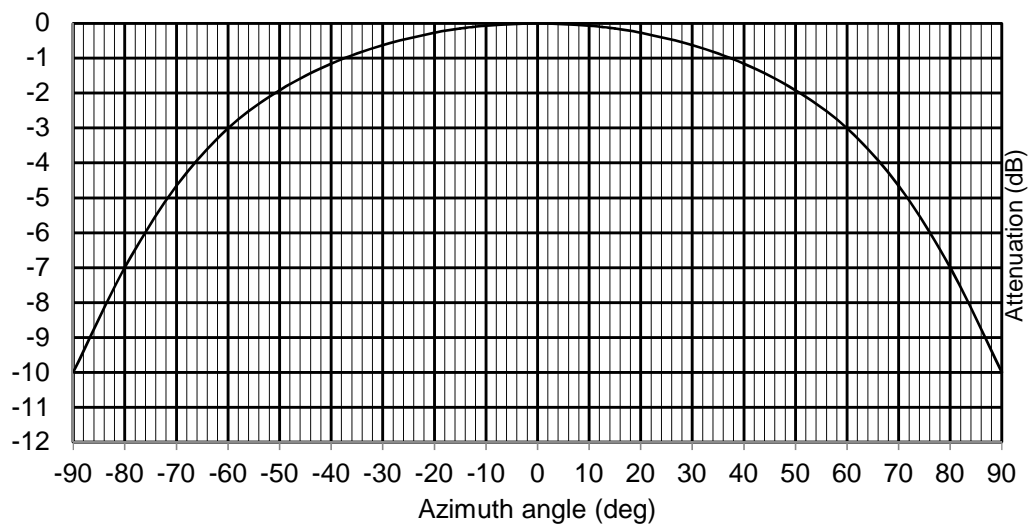

Figure 5: Minimum attenuation of the horizontal antenna pattern

Table 15: Minimum attenuation of the vertical/horizontal antenna pattern

| | | VERTICAL | HORIZONTAL |
|------------------------------|-------|----------|------------|
| ANGLE (ELEVATION OR AZIMUTH) | -90 | -30,0 | -10,0 |
| | -80 | -30,0 | -7,0 |
| | -70 | -28,0 | -4,7 |
| | -60 | -23,0 | -3,0 |
| | -50 | -18,2 | -1,9 |
| | -40 | -14,0 | -1,2 |
| | -30 | -9,5 | -0,6 |
| | -20 | -5,2 | -0,3 |
| | -15 | -3,2 | -0,2 |
| | -12,5 | -2,3 | -0,1 |
| | -10 | -1,6 | -0,1 |
| | 0 | 0,0 | 0,0 |
| | 10 | -1,6 | -0,1 |
| | 12,5 | -2,3 | -0,1 |
| | 15 | -3,2 | -0,2 |
| | 20 | -5,2 | -0,3 |
| | 30 | -9,5 | -0,6 |
| | 40 | -14,0 | -1,2 |
| | 50 | -18,2 | -1,9 |
| | 60 | -23,0 | -3,0 |
| 70 | -28,0 | -4,7 | |
| 80 | -30,0 | -7,0 | |
| 90 | -30,0 | -10,0 | |

4.6.1.4 Conformance

The conformance test suite for antenna pattern shall be as defined in clause 5.7 and not exceed the limits in clause 4.5.1.3. The difference between the limit curves and the measured values of the EUT antenna (the margin) shall be recorded in the test report.

5 Testing for compliance with technical requirements

5.1 Environmental conditions for testing

5.1.1 General

Tests defined in the present document shall be carried out at representative points within the boundary limits of the operational environmental profile defined by its intended use, which, as a minimum, shall be that specified in the test conditions contained in the present document.

Where technical performance varies subject to environmental conditions, tests shall be carried out under a sufficient variety of environmental conditions as specified in the present document to give confidence of compliance for the affected technical requirements.

5.1.2 Normal test conditions

Normal test conditions shall be as defined in clause A.5.3.1 of ETSI EN 303 883-1 [1].

5.1.3 Complete environmental profile test conditions

The complete environmental profile test conditions includes both the normal and extreme test conditions.

Normal test conditions shall be as defined in clause A.5.3.1 of ETSI EN 303 883-1 [1].

Extreme test conditions shall be as defined in clause A.5.3.2 of ETSI EN 303 883-1 [1] with a temperature range varying between -40 °C to +55 °C; the primary supply voltage varies from 90 to 110 % of the nominal value.

5.2 General conditions for testing

General guidance on conditions for testing, measurement uncertainty and interpretation of the measurement results are given in annex B.

5.3 Conformance test suites

ETSI EN 303 883-1 [1], annex B provides additional information on test setups for testing, e.g. radiated and conducted measurements. An overview for radiated measurements is provided in ETSI EN 303 883-1 [1], clause B.2.1.

5.4 Conformance methods of measurement for transmitter

5.4.1 General

The EUT shall be measured for:

- the operating frequency range (all);
- the mean e.i.r.p. (all);
- the mean e.i.r.p. spectral density (HD-GBSAR only);
- the TX unwanted emissions (all);
- the TX behaviour under the complete environmental profile (all).

5.4.2 Operating Frequency Range

The test shall be done inside an anechoic chamber, see ETSI EN 303 883-1 [1], clause B.2.2.2.

OFR measurement should be done with the same setup of clause 5.4.3 below and in the direction of the highest mean e.i.r.p. emission, using the conformance test in ETSI EN 303 883-1 [1], clause 5.2.2.

For the OFR conformance assessment, the value of X shall be as specified in clause 4.3.1.2 of the present document.

The measured results of the OFR shall be recorded.

5.4.3 Mean e.i.r.p.

The mean e.i.r.p. conformance test shall be inside an anechoic chamber, see ETSI EN 303 883-1 [1], clause B.2.2.2 and the test setup shall be based on the standard test method as described in ETSI EN 303 883-1 [1], clause B.4.

The conformance test procedure as specified in ETSI EN 303 883-1 [1], clause 5.3.1.3 shall be used.

The difference M between the mean e.i.r.p. limit in table 4 and the maximum of the measured results for the mean e.i.r.p. shall be calculated for each measurement direction around the device.

The direction of the maximum mean e.i.r.p. (that gives the smallest difference M), the measured results of the mean e.i.r.p. as well as the value of M of shall be recorded.

5.4.4 Mean e.i.r.p. Spectral Density

The test shall be inside an anechoic chamber, see ETSI EN 303 883-1 [1], clause B.2.2.2 and the test setup shall be based on the standard test method as described in ETSI EN 303 883-1 [1], clause B.4.

The conformance test procedure as specified in ETSI EN 303 883-1 [1], clause 5.3.2 shall be used.

The measured results of the mean e.i.r.p. spectral density shall be recorded.

5.4.5 TX unwanted emissions

Conformance shall be tested according to ETSI EN 303 883-1 [1], clause 5.5.3. If in the ETSI EN 303 883-1 [1], clause 5.5.3.1, step 1 the measurement results are above the limit of clause 4.3.4.3, proceed with step 2 in ETSI EN 303 883-1 [1], clause 5.5.3.1.

5.4.6 TX behaviour under the complete environmental profile

5.4.6.1 EUT with a 50 Ω transmitter output connector

Conformance shall be tested with the test-setup provided in figure 6 and performing conducted measurements according to ETSI EN 303 883-1 [1], clause B.3 and according to the procedure of clause 5.4.6.3.2.

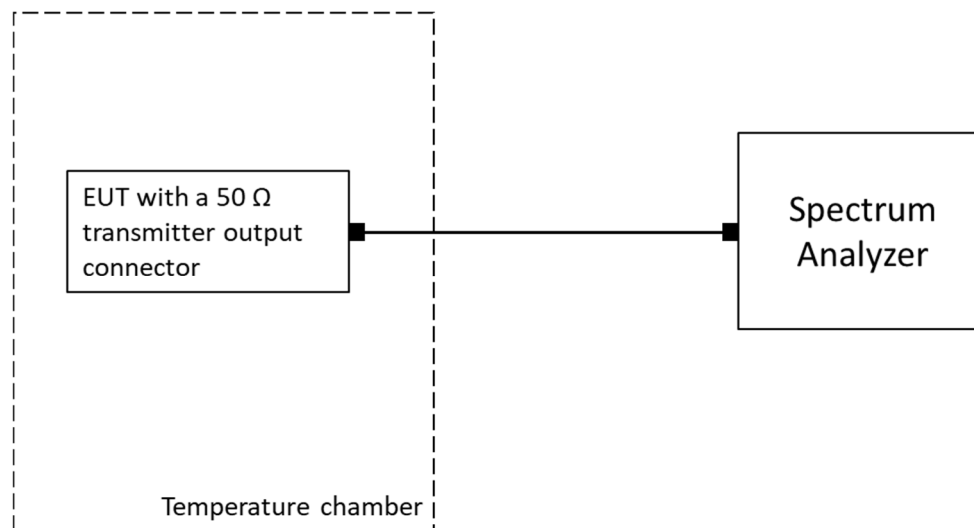

Figure 6: Setup for conducted measurements

5.4.6.2 EUT with integral or dedicated antenna

Conformance shall be tested with the EUT placed in a temperature test chamber and with the EUT directed in the direction with the smallest value of M towards the radio transparent door/wall of the chamber. Radiated measurements shall be performed according to ETSI EN 303 883-1 [1], clause A.5.3.2.3 and following the procedure of clause 5.4.6.3.3. The distance between the test antenna and the EUT shall be 3 meters.

5.4.6.3 Procedure for tests at extreme conditions

5.4.6.3.1 General

Before measurements are made the equipment shall have reached thermal balance in the temperature test chamber. The equipment shall be switched off during the temperature stabilizing period.

In the case of equipment containing temperature stabilization circuits designed to operate continuously, the temperature stabilization circuits shall be switched on for 15 minutes after thermal balance has been obtained, and the equipment shall then meet the specified requirements.

If the thermal balance is not checked by measurements, a temperature stabilizing period of at least one hour, or such period as may be decided by the accredited test laboratory, shall be allowed. The sequence of measurements shall be chosen, and the humidity content in the test chamber shall be controlled so that excessive condensation does not occur.

Tests performed under the complete environmental conditions shall be as specified in clause 5.1:

- a) at the extremes of the specified temperature range and at intervals of not more than 10° centigrade through the range and with the primary supply voltage set at the nominal level;
- b) at a temperature within the normal temperature range as defined in clause A.5.3.1 of ETSI EN 303 883-1 [1] and with the primary supply voltage set at 90 % and 110 % of the nominal value.

5.4.6.3.2 Conducted test procedure for EUT provided with a 50 Ω transmitter output connector

The test procedure shall be as follows:

- a) With the temperature test chamber and primary supply voltage set at normal test condition (see clause 5.1.2), the EUT shall be switched on and the mean power (see clause 5.4.3) value shall be recorded and stored as reference value R expressed in decibels.
- b) Set the primary supply voltage to the 90 % of the nominal value and store the value of the measured mean power as value MEP in decibels.
- c) Compute the difference MEP-R and compare with the limit of clause 4.3.5.3.
- d) Set the primary supply voltage to the 110 % of the nominal value and store the value of the measured mean power as value MEP in decibels.
- e) Compute the difference MEP-R and compare with the limit of clause 4.3.5.3.
- f) With the primary supply voltage set at the nominal value, program the temperature of the temperature test chamber at the lowest extreme of the specified temperature range of clause 5.1.3 and wait until thermal balance is attained. The equipment shall then be switched on in the transmit condition for a period sufficient to stabilize the measurement; the measured mean power in this condition shall be recorded and stored as value MEP.
- g) Compute the difference MEP-R and compare with the limit of clause 4.3.5.3.
- h) Increase the temperature of the chamber by 10 % of the temperature range as defined in clause 5.1.3 and repeat steps b) to g) until the highest extreme of the temperature range of clause 5.1.3 is reached.

5.4.6.3.3 Radiated test procedure for EUT with integral or dedicated antenna

The EUT shall be placed onto a radio transparent support, with the antenna directed toward the radio transparent door/wall of the chamber. The distance between the test antenna and the EUT shall be equal to 3 meters. Figure A.1 of ETSI EN 303 883-1 [1] shows a possible test setup.

The measuring test antenna shall be directed to the boresight of the EUT antenna and adjusted to capture the maximum of the mean e.i.r.p. produced by the EUT as identified in clause 5.4.3.

The test procedure shall be as follows:

- a) With the temperature test chamber and primary supply voltage set at normal test condition (see clause 5.1.2), the EUT shall be switched on and the mean e.i.r.p. value shall be recorded and stored as reference value R expressed in decibels.
- b) Set the primary supply voltage to the 90 % of the nominal value and store the value of the measured mean e.i.r.p. as value MEP in decibels.
- c) Compute the difference MEP-R and compare with the limit of clause 4.3.5.3.
- d) Set the primary supply voltage to the 110 % of the nominal value and store the value of the measured mean e.i.r.p. as value MEP in decibels.

- e) Compute the difference MEP-R and compare with the limit of clause 4.3.5.3.
- f) With the primary supply voltage set at the nominal value, program the temperature of the temperature test chamber at the lowest extreme of the specified temperature range of clause 5.1.3 and wait until thermal balance is attained. The equipment shall then be switched on in the transmit condition for a period sufficient to stabilize the measurement; the measured mean e.i.r.p. in this condition shall be recorded and stored as value MEP.
- g) Compute the difference MEP-R and compare with the limit of clause 4.3.5.3.
- h) Increase the temperature of the chamber by 10 % of the temperature range as defined in clause 5.1.3 and repeat steps b) to g) until the highest extreme of the temperature range of clause 5.1.3 is reached.

5.5 Conformance methods of measurement for receiver

5.5.1 General

The EUT shall be measured for:

- Receiver spurious emissions, see clause 5.5.2.
- Receiver Baseline Sensitivity (RBS), see clause 5.5.3.
- Receiver Baseline Resilience (RBR), see clause 5.5.4.

5.5.2 Receiver spurious emissions

Conformance shall be tested according to ETSI EN 303 883-2 [2], clause 5.2.3. In accordance with ETSI EN 303 883-2 [2] clause 5.2.2 the limit for Flower is 30 MHz, for F_{upper} see table 2 in ETSI EN 303 883-2 [2], clause 5.2.2. If the measurement results of step 1 are above the limit in clause 4.4.2.3, proceed with step 2 in ETSI EN 303 883-2 [2], clause 5.2.3.1.

For the test, the EUT shall be with the transmitter switched off (stand-by).

5.5.3 Receiver Baseline Sensitivity (RBS)

Conformity of RX Baseline Sensitivity shall be tested according to ETSI EN 303 883-2 [2], clause 5.4.3.5 ("Radiated Measurements for Radiodetermination Applications with Distance Limit") for the case of an integrated antenna as well as an available antenna port with dedicated antenna. The test shall be inside an anechoic chamber (see ETSI EN 303 883-2 [2], clause B.2.2.2) with the test-setup provided in figure 7.

The wanted technical performance criterion for the test is provided in clause 4.4.3.

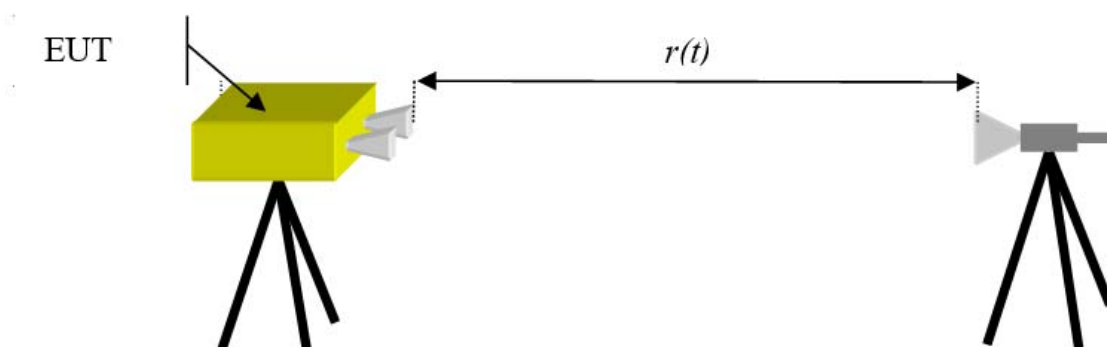

Figure 7: Setup for RBS measurement

The measurement distance $r(t)$ shall be as given in clause 4.4.4.3.

5.5.4 Receiver Baseline Resilience (RBR)

Conformity of Receiver Baseline Resilience shall be tested according to ETSI EN 303 883-2 [2], clause 5.5.3.5 ("Radiated Measurements for Radiodetermination Applications with Distance Limit") with the following parameters:

Interfering signal

No interfering signals within OFR are used (see explanation in annex D). Interfering signals outside OFR shall be as given in table C.4.

The setup shall be the same as used for the RBS test. The measurement distance $r(t)$ shall be as given in clause 4.4.5.3.

5.6 Conformance methods of measurement for spectrum access

5.6.1 General

The EUT shall be tested for:

- DAA for GBSAR, see clause 5.6.2.
- DAA for HD-GBSAR, see clause 5.6.3.

5.6.2 DAA for GBSAR

5.6.2.1 General

The following DAA test setup shall be used (see figure 8).

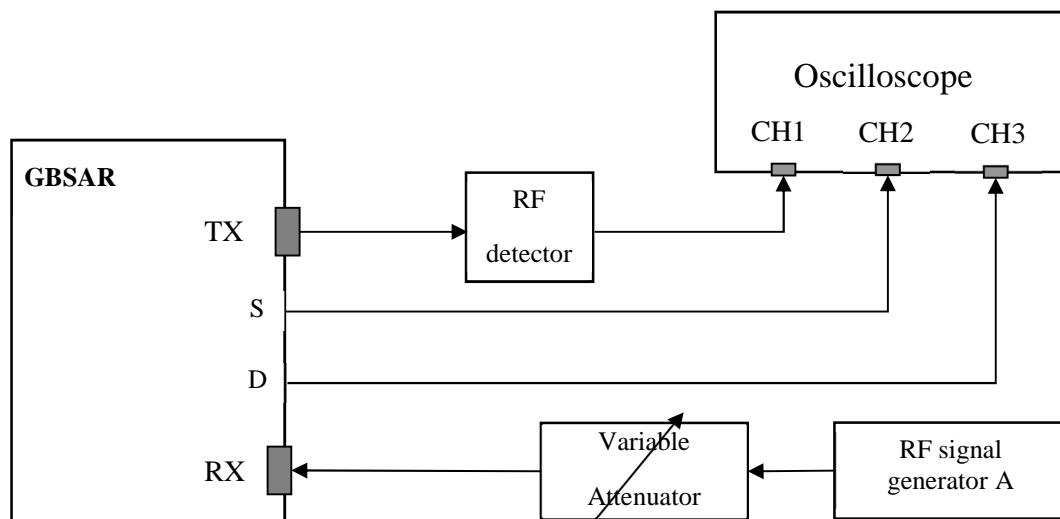

Figure 8: DAA measurement arrangement

The DAA test setup is composed by:

- An RF signal generator, A, is connected to GBSAR receiver antenna connector via appropriate attenuator. A variable attenuator is used to vary the output power of signal generator A into to the GBSAR receiver.
- GBSAR transmitter antenna connector is connected to channel 1 of a three channels oscilloscope via an RF detector. The detected RF signal measured by the oscilloscope will show when GBSAR is actually transmitting.

- c) GBSAR shall provide an output logic test signal, S, indicating when the intended operation command of GBSAR is started and stopped respectively. This signal is connected to channel 2 of the oscilloscope.
- d) GBSAR shall provide an output logic signal, D, indication when the level from the signal generator A is detected above and below the GBSAR receiver DAA threshold respectively. This signal shall be connected to channel 3 of the oscilloscope.

The signal generator A shall be able to generate all the test signals defined in clause 4.5.1.3, table 10.

The variable attenuator shall provide a range of at least 20 dB of attenuation in 1 dB steps.

5.6.2.2 Test procedure

5.6.2.2.1 General

In clause 5.6.2.2.2 the validation of test signal for the DAA test is specified.

The following clauses of the procedure below verifies the victim signal detection and avoidance capability for the GBSAR. It will verify:

- the DAA threshold, see clause 5.6.2.2.3;
- the DAA timing in the clause 5.6.2.2.4 (minimum listen time), clause 5.6.2.2.5 (minimum listen time after detection) and in clause 5.6.2.2.6 (maximum transmitter switch-off time).

5.6.2.2.2 Test signal

For validation of the DAA function the necessary characteristics of the RF test signals shall be as defined in clause 4.5.1.3, table 10.

5.6.2.2.3 DAA Threshold

The following procedure shall be used:

- a) The attenuator is set at the minimum attenuation (ideally 0 dB).
- b) A test signal according to clause 4.5.1.3, table 10 with a power level +10 dB above the DAA threshold limit is applied by the RF signal generator A.
- c) The time, t_0 , at which the transmitter is intended to be switched-on shall be noted at the oscilloscope on channel 2 of the oscilloscope.
- d) It shall be noted that a DAA level above its threshold is detected at channel 3 at the oscilloscope.
- e) The RF power level from the RF generator A is reduced in 1 dB steps by the increasing the attenuation of attenuator until a signal is not anymore detected on channel 3 of the oscilloscope.
- f) The resulting RF power level at GBSAR Rx antenna connector is calculated as the difference between the signal generator power level in dBm minus the attenuator value in dB. The final level (the DAA threshold) is noted and recorded in the test report.

The procedure a) to f) shall be made for each type of the four test signals according to clause 4.5.1.3, table 10.

5.6.2.2.4 Minimum Listen Time

The following test procedure shall be used:

- a) Set the attenuator at the maximum attenuation (at least 20 dB).
- b) A test signal according to clause 4.5.1.3, table 10 is applied by the RF signal generator A. The signal generator is switched on. The received power level at GBSAR Rx antenna connector shall be at least 10 dB below the DAA threshold limit, see clause 4.5.1.3, table 10.
- c) The GBSAR is intentionally switched on and the time, t_0 , is noted at channel 2 of the oscilloscope.

- d) The time, t_i , when the actual transmission is automatically switched-on is noted at channel 1 of the oscilloscope, The minimum listen time is calculated as: $t_D = t_i - t_0$.

The minimum listen time measured is illustrated at figure 9.

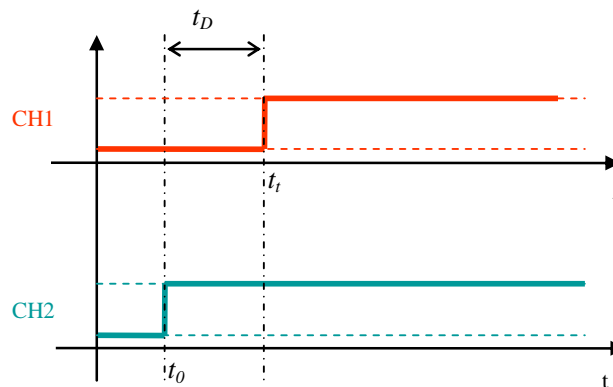

Figure 9: Minimum listen time, t_D , measurement

5.6.2.2.5 Minimum Listen Time after detection

The following test procedure shall be used:

- Set the attenuator at the minimum attenuation (ideally 0 dB).
- A test signal according to clause 4.5.1.3, table 10 is applied by the RF signal generator A. The power level at GBSAR Rx antenna connector shall be at least 10 dB above the DAA threshold. (The DAA threshold is defined in clause 4.5.1.3, table 10).
- The time, t_0 , at which the intended transmitter command is switch-on shall be noted at channel 2 of the oscilloscope, see figure 10.
- Note that a DAA level above the DAA threshold is detected at channel 3 at the oscilloscope and that no transmission is present by monitoring channel 1 at the oscilloscope, see figure 10. These facts shall be noted in the test report.
- By increasing the value of variable attenuator in steps of 1 dB, the power from the signal generator A to the GBSAR receiver antenna connector is reduced.
- When the power from the signal generator A at Rx antenna connector is reduced to 3 dB below the DAA threshold, then the time, t_S , shall be noted, see figure 10. The value of the attenuation shall also be noted.
- It shall be noted that a DAA level below the DAA threshold is detected at channel 3 at the oscilloscope.
- Note the time, t_i , when the transmitter is automatically switched-on at channel 1 of the oscilloscope.

The minimum listen time after detection, t_L , is calculated as $t_L = t_i - t_S$.

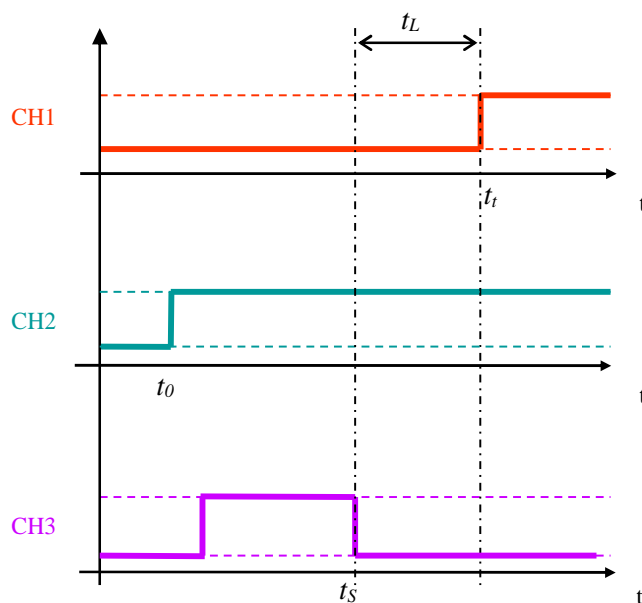

Figure 10: Minimum listen time after detection, t_L , measurement

5.6.2.2.6 Maximum transmitter switch-off time

The following test procedure shall be used:

- Set the attenuator at the maximum attenuation (at least 20 dB).
- A test signal according to clause 4.5.1.3, table 10 is applied by the RF signal generator A. The signal generator is switched on. The received power level at GBSAR Rx antenna connector shall be at least 10 dB below the DAA threshold limit, see clause 4.5.1.3, table 10.
- The GBSAR is intentionally switched on and the time, t_0 , is noted at channel 2 of the oscilloscope and the actual transmission is noted at channel 1 of the oscilloscope.
- The RF power level from the RF generator A is increased in 1 dB steps by decreasing the attenuation of attenuator until a DAA level above the DAA threshold is detected at channel 3 at t_s .
- Note that a signal is not anymore detected on channel 1 of the oscilloscope at t_e .
- The time, t_e when the actual transmission is automatically switched-off is noted at channel 1 of the oscilloscope, The transmitter switch-off time is calculated as: $t_{off} = t_s - t_e$.

The transmitter switch-off is illustrated at figure 11.

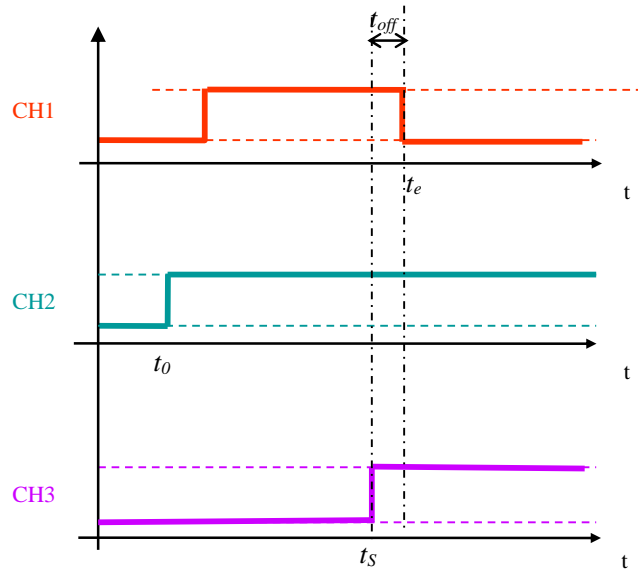

Figure 11: Maximum transmit switch-off time, t_{off} , measurement

5.6.3 DAA for HD-GBSAR

5.6.3.1 General

The following DAA test setup shall be used (see figure 12).

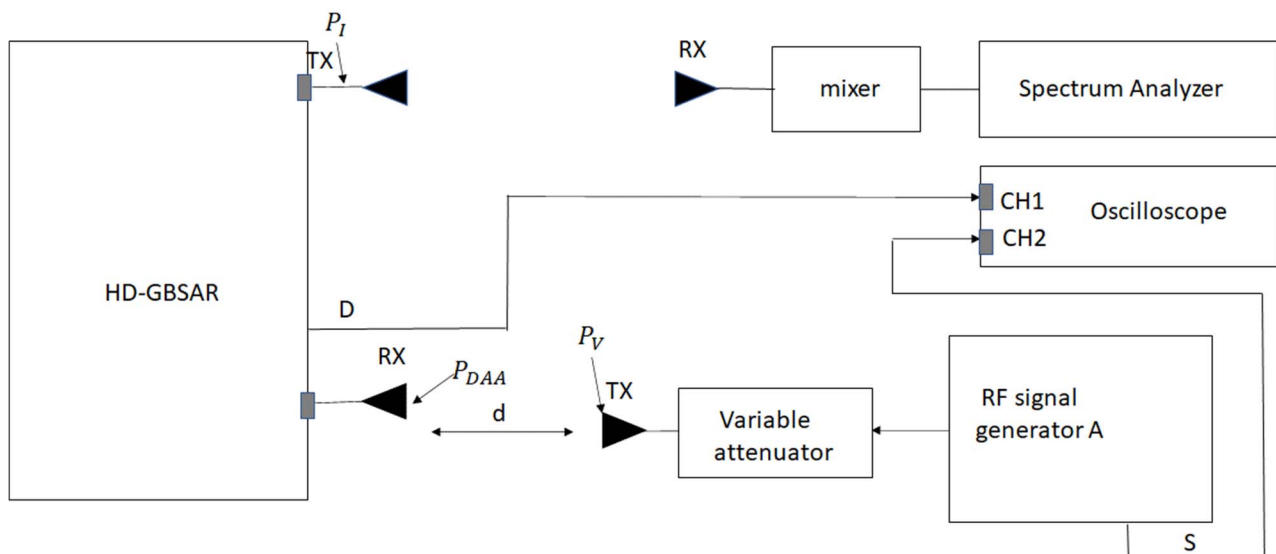

Figure 12: DAA measurement arrangement

The DAA test setup is composed by:

- An RF signal generator capable of varying the emitted power P_V with e.g. a variable attenuator. The antenna of such signal generator shall be pointed toward the HD-GBSAR receiving antenna.
- The signal generator A shall be programmed to generate a signal having a period and duty cycle as defined in clause 4.5.2.3, table 14. The timing of the generator shall be also available at channel 2 of the oscilloscope.
- Initially, the distance d between the signal generator A and the HD-GBSAR and P_V shall be adjusted to get the value of P_{DAA} provided in equation (1) of clause 4.5.2.3.

- d) A spectrum analyser is used to sense the HD-GBSAR transmitted signal to show when HD-GBSAR is transmitting.
- e) HD-GBSAR shall provide an output logic signal, D, indicating when the power of the HD-GBSAR received signal is above and below the DAA threshold P_{DAA} . This signal shall be connected to channel 1 of the oscilloscope.

The signal generator A shall be able to generate all the test signals defined in clause 4.5.2.3, table 14.

5.6.3.2 Test procedure

5.6.3.2.1 General

The procedure below verifies the victim signal detection and avoidance capability for the HD-GBSAR. It will verify:

- the DAA threshold;
- the Detect and Avoid timing, i.e. the stop of HD-GBSAR transmission within the time of a single radar measurement cycle (see table 13).

5.6.3.2.2 Test signal

For validation of the DAA function the necessary characteristics of the RF test signal shall be as defined in clause 4.5.2.3, table 14.

5.6.3.2.3 DAA Threshold and Timing

The following procedure shall be used:

- a) The HD-GBSAR shall be set to transmit as intended. The spectrum analyser shall be set as given in ETSI EN 303 883-1 [1], clause 5.3.1.3.
- b) The attenuator is set at the minimum attenuation (ideally 0 dB).
- c) A test signal according to clause 4.5.2.3, table 14 with a power level P_V^* which is +10 dB above the value P_V set initially, is generated by the signal generator A.
- d) Signal repetition time of the waveform generated by the RF generator A ($t_{ON} + t_{OFF}$) shall be noted on channel 2 of the oscilloscope.
- e) It shall be noted that a DAA level above its threshold is detected at channel 1 at the oscilloscope.
- f) The RF power level from the RF generator A is reduced in 1 dB steps by the increasing the attenuation of attenuator until the HD-GBSAR power is not anymore detected by the spectrum analyser.
- g) The difference Δ in time between the start of a repetition of the signal generated by the RF generator A and the time at which the signal D indicating the activation of DAA first appears on channel 1 of the oscilloscope, is noted and compared to the Radar measurement cycle in clause 4.5.2.2, table 13.
- h) The value of the attenuation is added to P_V^* and compared to the value P_V set initially.

The procedure a) to h) shall be made for each type of the two test signals according to clause 4.5.2.3, table 14.

The test is passed if Δ is not greater than the radar measurement cycle and if $P_V^* = P_V$.

5.7 Conformance methods of measurement for antenna

5.7.1 General

The measurements shall be made in an anechoic chamber and the setup in figure 13 shall be used.

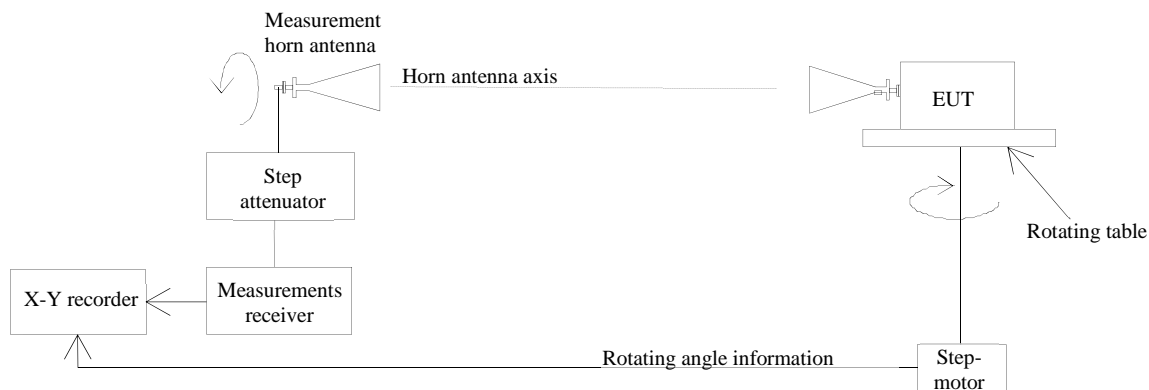

Figure 13: Test setup for measurement of antenna pattern

The measurement antenna shall be a linear polarized horn with at least 20 dB gain. The antenna shall be able to be rotated around its radiating axis, see figure 13. The measurements antenna is connected to a measurement receiver or spectrum analyser.

The distance between the measurement antenna and the EUT shall be sufficient to ensure that the measurements are conducted in the far-field, for further details see clause B.2.1 in ETSI EN 303 883-1 [1].

The Equipment Under Test (EUT) shall be placed on the rotating table to measure the horizontal antenna pattern, see figure 13.

5.7.2 Measuring distance

5.7.2.1 General

Under the conditions provided in this clause, measurement frequencies will be above 25 MHz and the measuring distance should be greater than $2D^2/\lambda$ or $\lambda/2$, whichever is greater, at the frequency of measurement where D is the largest transmitting aperture dimension (far-field conditions).

5.7.2.2 Standard position

The standard position in all test sites, except for equipment which is intended to be worn on a person, shall be as follows:

- for equipment with an integral antenna, it shall be placed in the position closest to normal use as specified in the operator's manual of the EUT;
- for equipment with a rigid external antenna, the antenna orientation shall be vertical;
- for equipment with non-rigid external antenna, the antenna shall be supported by a non-conducting support at the initial height of the test antenna.

5.7.2.3 Auxiliary cables

The position of auxiliary cables (power supply and microphone cables, etc.) which are not adequately de-coupled, may cause variations in the measurement results. In order to get reproducible results, cables and wires of auxiliaries should be arranged vertically downwards (through a hole in the non-conducting support), or as specified in the technical documentation supplied with the equipment.

5.7.3 Test procedure

The following steps shall be followed:

- a) The transmitter shall be switched-on. In case of EUT implementing more than one transmitter operating simultaneously, all the transmitters shall be switched on.
- b) The measurement antenna shall be adjusted to same height as the antenna for the EUT.
- c) The measurement antenna shall be adjusted in the direction of the antenna for the EUT.
- d) The equipment antenna shall be adjusted in the direction of maximum reading at the measurement antenna. The direction on the rotating table is the reference direction (0° on the rotating table).
- e) The measurement antenna is rotated around its axis for maximum reading at the measurement receiver. The reading is the reference reading (0 dB).
- f) The rotating table is rotated from -90° via 0° to $+90^\circ$ and the corresponding readings on the measurement receiver shall be recorded. Any peaks reading of sidelobes shall specifically be recorded.
- g) The measurement antenna is rotated 90° around its axis.
- h) The measurement step f) shall be repeated.
- i) The transmitter is switched-off. In case of EUT implementing more than one transmitter operating simultaneously, all the transmitters shall be switched off.
- j) The equipment under test is mounted sideways on the rotating table (tilted by 90°) to simulate measurements of vertical antenna elevation, see figure 13.
- k) The transmitter shall be switched-on. In case of EUT implementing more than one transmitter operating simultaneously, all the transmitters shall be switched on.
- l) The measurement antenna shall be adjusted to same height as the antenna for the EUT.
- m) The measurement antenna shall be adjusted in the direction of the antenna for the EUT.
- n) The equipment antenna shall be adjusted in the direction of maximum reading at the measurement antenna. The direction on the rotating table is the reference direction (0° on the rotating table).
- o) The measurement antenna is rotated around its axis for maximum reading at the measurement receiver. The reference reading is the same as in d) above (0 dB).
- p) The rotating table is rotated from -90° via 0° to $+90^\circ$ and the corresponding readings on the measurement receiver shall be recorded. Any peaks reading of sidelobes shall specifically be recorded.
- q) The measurement antenna is rotated 90° around its axis.
- r) The measurement step p) shall be repeated.
- s) The transmitter is switched-off. In case of EUT implementing more than one transmitter operating simultaneously, all the transmitters shall be switched off.

The above results in total four antenna pattern measurements. The measurements a) to i) cover the horizontal antenna pattern measurements. The measurements j) to s) cover the vertical antenna pattern. The results shall be noted in the test report.

Annex A (informative): Relationship between the present document and the essential requirements of Directive 2014/53/EU

The present document has been prepared under the Commission's standardisation request C(2015) 5376 final [i.6] to provide one voluntary means of conforming to the essential requirements of Directive 2014/53/EU on the harmonisation of the laws of the Member States relating to the making available on the market of radio equipment and repealing Directive 1999/5/EC [i.1].

Once the present document is cited in the Official Journal of the European Union under that Directive, compliance with the normative clauses of the present document given in table A.1 confers, within the limits of the scope of the present document, a presumption of conformity with the corresponding essential requirements of that Directive and associated EFTA regulations.

Table A.1: Relationship between the present document and the essential requirements of Directive 2014/53/EU [i.1]

| Harmonised Standard ETSI EN 303 661 | | | | | |
|-------------------------------------|---|-------------------------------------|-----------------------------------|----------------------------|---------------|
| Requirement | | | | Requirement Conditionality | |
| No | Description | Essential requirements of Directive | Clause(s) of the present document | U/C | Condition |
| 1 | Operating Frequency Range (OFR) | 3.2 | 4.3.1 | U | |
| 2 | Mean e.i.r.p. | 3.2 | 4.3.2 | U | |
| 3 | Mean e.i.r.p. spectral density | 3.2 | 4.3.3 | C | HD-GBSAR only |
| 4 | TX unwanted emissions | 3.2 | 4.3.4 | U | |
| 5 | TX behaviour under the complete environmental profile | 3.2 | 4.3.5 | U | |
| 6 | Receiver spurious emissions | 3.2 | 4.4.2 | U | |
| 7 | Receiver Baseline Sensitivity (RBS) | 3.2 | 4.4.4 | U | |
| 8 | Receiver Baseline Resilience (RBR) | 3.2 | 4.4.5 | U | |
| 9 | DAA for GBSAR | 3.2 | 4.5.1 | C | GBSAR only |
| 10 | DAA for HD-GBSAR | 3.2 | 4.5.2 | C | HD-GBSAR only |
| 11 | Antenna pattern | 3.2 | 4.6.1 | C | GBSAR only |

Key to columns:

Requirement:

No A unique identifier for one row of the table which may be used to identify a requirement.

Description A textual reference to the requirement.

Essential requirements of Directive

Identification of article(s) defining the requirement in the Directive.

Clause(s) of the present document

Identification of clause(s) defining the requirement in the present document unless another document is referenced explicitly.

Requirement Conditionality:

| | |
|------------------|---|
| U/C | Indicates whether the requirement is unconditionally applicable (U) or is conditional upon the manufacturer's claimed functionality of the equipment (C). |
| Condition | Explains the conditions when the requirement is or is not applicable for a requirement which is classified "conditional". |

Presumption of conformity stays valid only as long as a reference to the present document is maintained in the list published in the Official Journal of the European Union. Users of the present document should consult frequently the latest list published in the Official Journal of the European Union.

Other Union legislation may be applicable to the product(s) falling within the scope of the present document.

Annex B (informative): General conditions for testing, measurement uncertainty and interpretation of the measurement results

General guidance on testing TX and RX measurements are given respectively in ETSI EN 303 883-1 [1], clause 5.1.1 for the TX requirements and ETSI EN 303 883-2 [2], clause 5.1 for the RX requirements.

ETSI EN 303 883-1 [1], annex A provides additional information on general conditions for testing, e.g. test environment and test conditions, measurement uncertainty and interpretation of the measurement results. An overview is provided in ETSI EN 303 883-1 [1], clause A.1.

Annex C (normative): Use-Case, wanted technical performance criterion and RX-test conditions

C.1 Description

GBSAR and HD-GBSAR covered by this annex C are designed to detecting a movement of landslides or structures potentially affecting the protection of workers and the general public.

C.2 Wanted Technical Performance Criterion (WTPC) and RX - requirement

C.2.1 General

This annex provides information regarding the selected parameters for the Wanted Technical Performance Criterion used in clause 4.4.

The minimum requirement for GBSAR and HD-GBSAR EUT shall be to measure the movement of a reference target with the desired accuracy.

This is obtained by using the differential interferometry technique which consists in the use of the phase information of each radar pixel in the monitored scenario to measure the surface deformation along the line of sight.

The accuracy in measuring this displacement σ_r is related to the accuracy in measuring phase differences σ_φ by the equation (C.1) below:

$$\sigma_r = \frac{c}{4\pi \cdot f_0} \cdot \sigma_\varphi \quad (\text{C.1})$$

where f_0 is the central frequency of the transmitted signal, c is speed of light in the propagation medium.

From the equation above, it is understandable that σ_r is affected by variation of:

- frequency of the transmitted signal;
- propagation speed;

accuracy in measuring the interferometric phase σ_φ .

In the evaluation of the limits for the RBS/RBR tests, the first two factors are neglected because:

- the frequency stability is a requirement for some of the compliance tests in the present document (e.g. the OFR);
- the variation of the propagation speed can be due to some atmospheric events only (for instance temperature, humidity and pressure) and are not due to the EUT.

In order to get an evaluation of the error σ_φ which is intrinsic to the EUT (and hence to the receiver), the setup shall be designed to assure that the reflection from a reference target (for instance a corner reflector) is strong enough to limiting the contribution to σ_φ by other factors (for instance the reflection from the wall of the testing chamber).

In order to do so a large (> 80 dB) signal to noise ratio - SNR is required for performing a correct evaluation and, hence, of the receiver sensitivity.

A suitable reference target featuring the required SNR, is the trihedral corner reflector with sides comprised of isosceles right triangles; for such target, the RCS can be calculated using geometrical optics as:

$$RCS_{triangle,peak} = \frac{4\pi a^4}{3\lambda^4} \quad (C.2)$$

where λ is the nominal wavelength and a is the side of the triangles.

For instance, a trihedral corner reflector with a side of 15 cm, has a RCS of 8 dBsqm at a frequency of 17 GHz. Such target, placed at a distance D_{sense} of 6 m from the EUT, provides a SNR large enough for our scope (> 90 dB) and is used as reference for the RBS/RBR tests.

Hence, the wanted technical performance criterion for GBSAR/HD-GBSAR EUT is defined as Error in Distance Measurement (EDM); it is evaluated as the root mean squared error of the measured distance $r(t)$ versus the nominal distance D_{sens} of the reference target, i.e.:

$$EDM = \sqrt{E\{(r(t) - D_{sense})^2\}} \quad (C.3)$$

C.2.2 RBS-requirement and limit

The requirement for the distance r of the reference object and duration of the measurement are provided in table C.1, the kind of object is specified in table C.2 and the limit for EDM is given in table C.3.

The evaluated EDM shall be lower than the requirement EDM_{max} given in table C.3.

Table C.1: Requirement for object distance r and duration of the measurement for the RBS test

| Category | $D_{sense}[m]$ | Duration of the measurement |
|----------|----------------|-----------------------------|
| GBSAR | 6 | 10 minutes |
| HD-GBSAR | 6 | 10 minutes |

Table C.2: Requirement for kind of object for RBS test

| Category | Kind |
|----------|---|
| GBSAR | Trihedral corner reflector with a side of 15 cm |
| HD-GBSAR | Trihedral corner reflector with a side of 15 cm |

Table C.3: Requirement for EDM evaluated on the duration of the measurement for RBS test

| Category | EDM_{max} [mm] |
|----------|------------------|
| GBSAR | 0,1 |
| HD-GBSAR | 0,1 |

C.2.3 RBR requirement and limit

Based on the specified RBS scenario (see clause C.2.2) the limits for EDM for the RBR test are provided in table C.4.

The evaluated EDM shall be lower than the requirement EDM_{max} given in table C.4.

Table C.4: Requirement for EDM evaluated on the duration of the measurement for RBR test

| Category | EDM_{max} [mm] |
|----------|------------------|
| GBSAR | 0,12 |
| HD-GBSAR | 0,12 |

NOTE: The RBR requirement considers a 20 % maximum degradation for EDM.

Annex D (normative): Interferer for RBR test

D.1 Interferer requirements for RBR tests

D.1.1 General test frequencies for RBR tests

ETSI EN 303 883-2 [2], clause A.2, usually defines the test frequencies inside and outside the OFR.

However, EUT covered by the present document are required to implement a DAA for the frequencies inside the OFR (see clause 4.5.1 for the GBSAR and clause 4.5.2 for the HD-GBSAR). Therefore, the EUT will not operate in case of an interferer falling within the OFR and the RBR test shall not apply.

For interferers outside OFR:

- for GBSAR EUT: see clause D.1.2;
- for HD-GBSAR EUT: see clause D.1.3.

Justification in terms of the of receiver requirements given in ETSI EN 303 883-2 [2], clause C.1 is valid for the EUT covered by the present document.

D.1.2 Test frequencies for GBSAR

In accordance with ETSI EN 303 883-2 [2], clause A.2.2, the following interfering signal characteristics are defined:

Interfering signal frequency at $f_c \pm (X)$ with $X = 1 \text{ \& } 2$.

- Modulation of interfering signal: CW.
- Level of interfering signal: the same power level from the worst-case interferer within OFR shall be used.

Clause 7.2 in ETSI TS 103 361 [i.4] does not list interferers in the GBSAR OFR with power levels higher than the GBSAR itself. Thus, the EFIS database [i.11] was consulted as required in clause A.2.1.1 of ETSI EN 303 883-2 [2]. According to that, the frequencies between 15,7 GHz and 17,7 GHz are listed with the footnote ECA36 in the European Table Of Frequency Allocations And Utilizations (see the EFIS database [i.11]), meaning that those frequency bands have been harmonised by NATO and NATO member nations for military use.

Table 3 of ECC Report 111 [i.7] contains technical characteristics of representative radiolocation radars deployed in the that frequency range which were used to set the DAA thresholds (see table 11 in clause 4.5.1.3 of the present document).

Thus, the level of interfering signal listed in table D.1 below corresponds to the test signal 3 of table 11 in clause 4.5.1.3 of the present document.

Table D.1: RBR limits outside OFR for the GBSAR EUT

| Interference power level at EUT | Test frequencies | Modulation of test signals |
|---------------------------------|--|----------------------------|
| -45 dBm | <ul style="list-style-type: none"> • $f_c - 2 \times \text{OFR}$ • $f_c - 1 \times \text{OFR}$ • $f_c + 1 \times \text{OFR}$ • $f_c + 2 \times \text{OFR}$ | CW |

D.1.3 Test frequencies for HD-GBSAR

In accordance with ETSI EN 303 883-2 [2], clause A.2.2, the following interfering signal characteristics are defined:

Interfering signal frequency at $f_c \pm (X)$ with $X = 1 \text{ \& } 2$.

- Modulation of interfering signal: CW.
- Level of interfering signal: the same power level from the worst-case interferer within OFR shall be used.

Clause 7.2 in ETSI TS 103 361 [i.4] lists 5 possible interferers in the HD-GBSAR OFR with power levels varying between 34 dBm to 55 dBm.

The level of interfering signal reported in table D.2 was computed according to the worst-case scenario, using equation (2) in clause 7.3 of ETSI TS 103 361 [i.4] where $d = 2 \text{ m}$ (mobile application) and $p = 55 \text{ dBm}$.

An additional loss NLOS [dB] = 10 dB is also added according to clause 7.6 of ETSI TS 103 361 [i.4].

Fixed Services with centre frequency at 73,5 GHz and 83,5 GHz and power level of 85 dBm were also considered in this evaluation, leading, however, to a lower interference power level.

Table D.2: RBR limits outside OFR for the HD-GBSAR EUT

| Interference power level at EUT | Test frequencies | Modulation of test signals |
|---------------------------------|--|----------------------------|
| -31 dBm | <ul style="list-style-type: none"> • $f_c - 2 \times \text{OFR}$ • $f_c - 1 \times \text{OFR}$ • $f_c + 1 \times \text{OFR}$ • $f_c + 2 \times \text{OFR}$ | CW |

Annex E (informative): Test signals for the HD-GBSAR DAA

E.1 General

The ECC decision ECC/DEC/(21)02 [i.9] setting the conditions for the harmonised use of the HD-GBSAR, establishes that the HD-GBSAR devices implement a Detect And Avoid (DAA) system capable to detect automotive radar signals operating in the band 76 GHz to 77 GHz and to stop HD-GBSAR transmission, in case of automotive radar detection.

This annex provides information regarding the selected test signals to be used in the conformance test of the HD-GBSAR DAA.

E.2 Interference with automotive radar signals

E.2.1 Characteristics of automotive radar signals

Characteristics of the automotive radar to be considered for DAA are generically defined in table 2 of ECC/DEC/(21)02 [i.9]. They use a FMCW modulation and have an occupied RF bandwidth varying from 100 MHz to 1 GHz (according to the specific mission), as well as different frequency sweep time (slow/fast) and duty cycle (ratio between Transmitter On/Off time).

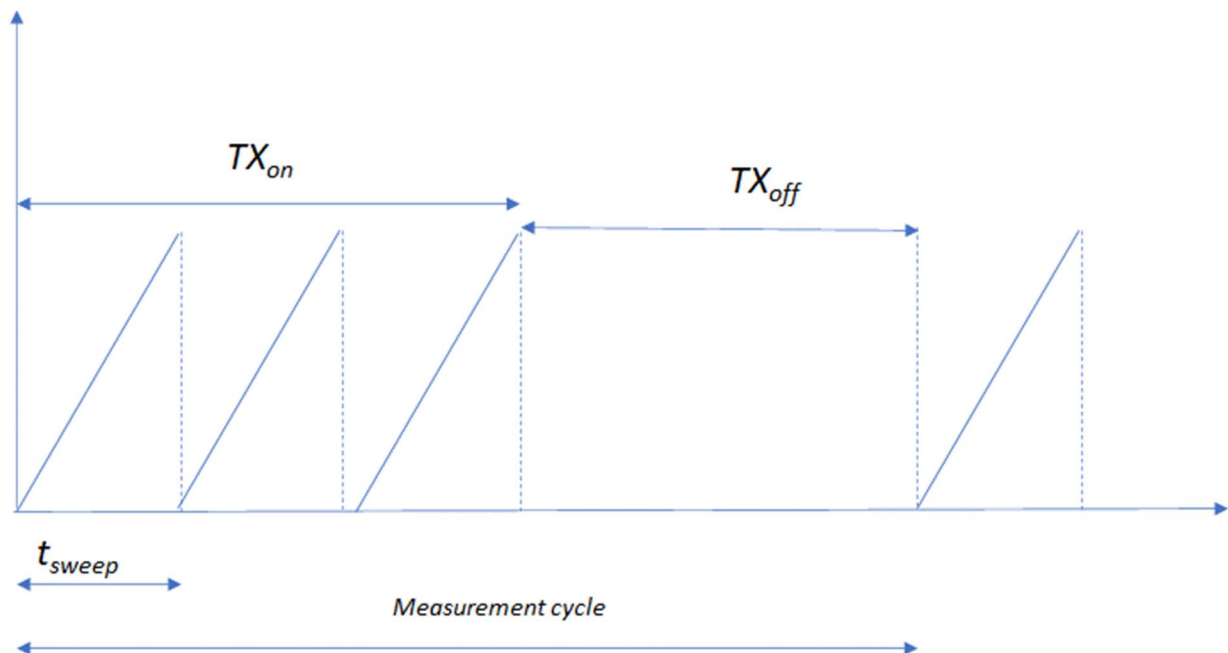

Figure E.1: Example of an automotive radar signal

More information are given in table E.1 below that is taken from table 3 of ECC Report 262 [i.10].

Table E.1: Relevant automotive radar signal parameters (ECC Report 262 [i.10], table 3)

| | Front Long range | Front Mid range | Front-side Mid and short range | Rear-side Mid and short range |
|---|--|---------------------|--|--|
| Max operating range at 10 dBsm target size | 250 m | 160 m | 100 m | 100 m |
| Antenna height above road | 0,2 m to 1,0 m | | 0,3 m to 1,2 m | |
| Antenna lateral offset from vehicle centre | Up to ± 1 m | | | |
| Antenna orientation with respect to driving direction | 0°/0° | 0°/0° | 0°/ $\pm 30^\circ$ | 0°/ $\pm 135^\circ$ |
| Antenna polarization | Horizontal vertical diagonal | Horizontal vertical | | |
| Tx modulation type | Slow FMCW, Fast FMCW | | | |
| Occupied RF bandwidth (typical) | 100 MHz to 250 MHz | 500 MHz | Mid range: 500 MHz Short range: up to 1 GHz | Mid range: 500 MHz Short range: up to 1 GHz |
| Tx frequency sweep time (typical) | Slow FMCW: 1 ms to 20 ms; Fast FMCW: 20 μ s to 80 μ s | | | |
| Tx antenna feed power (typical) | 10 dBm | | | |
| Tx/Rx antenna max. gain (single element) | 20 dBi to 25 dBi | 15 dBi to 20 dBi | 15 dBi | 15 dBi |

Characteristics of the HD_GBSAR signal considered in this analysis can be found in table E.2 taken from table 2 of ECC Report 315 [i.8].

Table E.2: HD-GBSAR signal characteristics (ECC Report 315 [i.8], table 2)

| Parameter | Value |
|---------------------|--|
| Modulation | Linear Frequency Modulated Continuous Wave (LFMCW) |
| Central frequency | Tuneable between 74,5 GHz and 80,5 GHz |
| Emissions bandwidth | 1 GHz |
| Sweep duration | 1 ms |

E.2.2 Interference between two FMCW signals

In order to evaluate the interference between two FMCW signals, the following situation is considered:

- Victim: FMCW signal with bandwidth B_V and sweep duration t_V (with a slope $k_1 = B_V/t_V$)
- Interferer: FMCW signal with bandwidth B_I and sweep duration t_I (with a slope $k_2 = B_I/t_I$)

to establish the persistence in the victim Intermediate Frequency (IF) filter of the demodulated signal resulting from the mixing these FMCW signals (victim and interferer).

Therefore, the duration of time during which the frequency difference is smaller than the IF bandwidth is computed according to:

$$|f_I(t) - f_V(t)| < B_{IF} \quad (\text{E.1})$$

Referring to figure E.2 below, this leads to:

$$f_I(t) = \frac{B_I}{T_I} t + f_c \quad (\text{E.2})$$

$$f_V(t) = \frac{B_V}{T_V} t + f_c \quad (\text{E.3})$$

Hence:

$$\left| \frac{B_I}{T_I} - \frac{B_V}{T_V} \right| t < B_{IF} \quad (\text{E.4})$$

Having defined the slope k for the 2 interfering ramps:

$$k_I = \frac{B_I}{T_I} \quad (\text{E.5})$$

$$k_V = \frac{B_V}{T_V} \quad (\text{E.6})$$

the duration of the interference becomes:

$$t < \frac{B_{IF}}{|k_I - k_V|} \quad (\text{E.7})$$

that needs to be multiplied with a factor 2 for considering the left and right interval with respect to f_c .

So, finally:

$$t_{cross} = \frac{2 \cdot B_{IF}}{|k_I - k_V|} \quad (\text{E.8})$$

Thus, as smaller the difference in the slopes of the ramps, as longer the duration of the interference in the IF filter of the victim receiver.

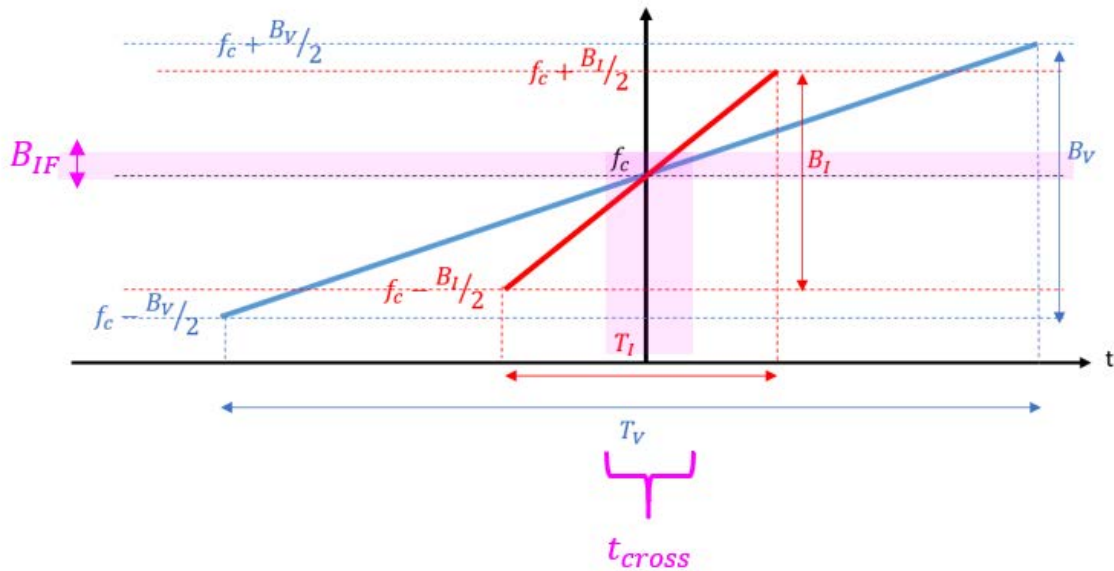

Figure E.2: Crossing time t_{cross} between interfering signals

E.2.3 Selection of the test signals for the HD-GBSAR DAA

Basing on the characteristics of the automotive radar signals in table E.1, the slope k can be computed for the long-mid range radars, as well as for the short-mid range ones.

Table E.3: k for different type of automotive radar signals

| | Slow | Fast |
|--|--|--|
| $B = 100 - 500$ MHz (Long-mid range) | $5 \times 10^9 < k < 5 \times 10^{11}$ | $1,25 \times 10^{12} < k < 2,5 \times 10^{13}$ |
| $B = 500$ MHz - 1 GHz (Short-mid range) | $2,5 \times 10^{10} < k < 10^{12}$ | $6,25 \times 10^{12} < k < 5 \times 10^{13}$ |

For the HD-GBSAR, the parameter k can be computed basing of the characteristics in table E.2, hence:

$$k_{HD-GBSAR} = \frac{1 \text{ GHz}}{1 \text{ ms}} = 10^{12} \quad (\text{E.9})$$

Thus, the worst case scenario to be considered for the HD-GBSAR DAA conformance test, is with automotive signals having a factor k similar to $k_{HD-GBSAR}$, thus $k \cong 10^{12}$. This corresponds to the:

- "Long-mid range fast" radar signal
- "Short-mid range slow" radar signal

cases in table E.3.

Hence, having selected $k = 10^{12} \pm 25\%$, the following test signals are selected.

Table E.4: Test signals for the HD-GBSAR DAA

| Parameter | Unit | Type 1 | Type 2 |
|---|---------------|--------|--------|
| Modulation | | FMCW | FMCW |
| Frequency | GHz | 76,5 | 76,5 |
| Occupied RF bandwidth | MHz | 100 | 1 000 |
| Single frequency sweep time (slow FMCW) | ms | --- | 1,3 |
| Single frequency sweep time (fast FMCW) | μs | 80 | -- |
| Period of the test signal | ms | 50 | 50 |
| Duty cycle | % | 50 | 50 |

Finally, ECC/DEC/(21)02 [i.9] sets the DAA threshold to be implemented, in detail:

$$P = -70,8 - P_I \text{ dBm} \quad (\text{E.10})$$

where P_I is the HD-GBSAR conducted peak power at the transmitter antenna input in dBm.

Annex F (informative): Mapping requirements

ETSI EG 203 336 [i.12], clause 5 lists the technical parameters applicable to transmitters and receivers that should be considered when producing Harmonised Standards that are intended to cover the essential requirements in article 3.2 of Directive 2014/53/EU [i.1]. Essential requirements are high level objectives described in European Directives. The purpose of the Harmonised Standard is to translate those high level objectives into detailed technical specifications. Table F.1 contains the parameters listed in ETSI EG 203 336 [i.12], clause 5 for transmitter and receiver, and cross references these to the clauses within the present document in which the requirements for measurement of such parameters are satisfied or justified.

Table F.1: Cross reference of clauses in the present document to technical parameters for transmitter and receiver listed in ETSI EG 203 336 [i.12]

| ETSI EG 203 336 [i.12] | | Present document | | Justification |
|------------------------|--|------------------|---------------------------------------|--|
| Clause | Parameter | Clause | Parameter | |
| 5.2.2 | Transmitter power limits | 4.3.2 | Mean e.i.r.p. | See related regulation in 2022/180/EU [i.3] and ECC/DEC/(21)02 [i.9]. |
| | | 4.3.3 | Mean power spectral density e.i.r.p. | |
| | | 4.6.1 | Antenna pattern | See related regulation in 2022/180/EU [i.3]. |
| 5.2.3 | Transmitter power accuracy | - | - | As stated in ETSI EG 203 336 (V1.2.1) [i.12] "When regulatory limits imply only a maximum emission limit (e.g. products that operate under a general licence regime), this parameter need not be considered for inclusion in an HS." |
| 5.2.4 | Transmitter spectrum mask | 4.3.1 | Operating Frequency Range | |
| 5.2.5 | Transmitter frequency stability | - | - | Not applicable. |
| 5.2.6 | Transmitter intermodulation attenuation | - | - | From ETSI EG 203 336 (V1.2.1) [i.12] this parameters is required only "where high levels of quality services are required". This is not relevant for generic short range devices which are operating under licence except regime without any kind of regulatory protection. SRDs have to accept interferences. |
| 5.2.7.2 | Transmitter unwanted emissions in the out of band domain | 4.3.4 | TX Unwanted emissions | |
| 5.2.7.3 | Transmitter unwanted emissions in the spurious domain | 4.3.4 | TX Unwanted emissions | |
| 5.2.8 | Transmitter time domain characteristics | - | - | Not applicable. |
| 5.2.9 | Transmitter transients | - | - | Not applicable. |
| | Other mitigation, spectrum access requirements not specified in the ETSI Guide but specified in related ECC/EC framework | 4.5 | DAA | |
| 5.3.2 | Receiver sensitivity | | not specified, superseded by RBS test | See justification in ETSI EN 303 883-2 [2], Annex C and the explanation of the interferer signal handling concept, see ETSI TS 103 567 [i.13]. |

| ETSI EG 203 336 [i.12] | | Present document | | Justification |
|------------------------|--|------------------|---|---|
| Clause | Parameter | Clause | Parameter | |
| 5.3.2.3 | Desensitization | | not specified, superseded by RBR test | See justification in ETSI EN 303 883-2 [2], Annex C and the explanation of the interferer signal handling concept, see ETSI TS 103 567 [i.13]. |
| 5.3.3 | Receiver co-channel rejection | | not specified, superseded by RBR test | See justification in ETSI EN 303 883-2 [2], Annex C and the explanation of the interferer signal handling concept, see ETSI TS 103 567 [i.13]. |
| 5.3.4.2.1 | Receiver adjacent channel selectivity | | not specified, superseded by RBR test | See justification in ETSI EN 303 883-2 [2], Annex C and the explanation of the interferer signal handling concept, see ETSI TS 103 567 [i.13]. |
| 5.3.4.2.2 | Receiver adjacent band selectivity | - | not specified, superseded by RBR test | See justification in ETSI EN 303 883-2 [2], Annex C and the explanation of the interferer signal handling concept, see ETSI TS 103 567 [i.13]. |
| 5.3.4.3 | Receiver blocking | - | not specified, superseded by RBR test | See justification in ETSI EN 303 883-2 [2], Annex C and the explanation of the interferer signal handling concept, see ETSI TS 103 567 [i.13]. |
| 5.3.4.4 | Receiver spurious response rejection | - | not specified, superseded by RBR test | See justification in ETSI EN 303 883-2 [2], Annex C and the explanation of the interferer signal handling concept, see ETSI TS 103 567 [i.13]. |
| 5.3.4.5 | Receiver radio-frequency intermodulation | - | not specified, superseded by RBR test | See justification in ETSI EN 303 883-2 [2], Annex C and the explanation of the interferer signal handling concept, see ETSI TS 103 567 [i.13]. |
| 5.3.5 | Receiver unwanted emissions in the spurious domain | 4.4.2 | Receiver spurious emissions | |
| 5.3.6.1 | Receiver dynamic range | 4.4.4 | Partly covered by RBS | See justification in ETSI EN 303 883-2 [2], table C.1. |
| 5.3.6.2 | Reciprocal mixing | - | not specified, superseded by RBR test | See justification in ETSI EN 303 883-2 [2], Annex C and the explanation of the interferer signal handling concept, see ETSI TS 103 567 [i.13]. |
| | Signal interferer handling | 4.4.4 4.4.5 | Receiver Baseline Sensitivity (RBS) Receiver Baseline Resilience (RBR) | Interferer signal handling is an alternative method for specifying receiver parameters and it is intended for use for UWB receivers and for certain types of radar equipment. The present document is following this concept, see ETSI TS 103 567 [i.13] and ETSI EN 303 883-2 [2]. |

Annex G (informative): Bibliography

- ETSI EN 300 440 (V2.1.1): "Short Range Devices (SRD); Radio equipment to be used in the 1 GHz to 40 GHz frequency range; Harmonised Standard covering the essential requirements of article 3.2 of Directive 2014/53/EU".

Annex H (informative): Change history

| Version | Information about changes |
|---------|--|
| V0.1.2 | First version produced under RED Directive |
| | |
| | |

History

| Document history | | | |
|-------------------------|---------------|-----------------------|---------------------------------------|
| V1.1.0 | February 2023 | EN Approval Procedure | AP 20230517: 2023-02-16 to 2023-05-17 |
| V1.1.1 | March 2024 | SRdAP process | VA 20240519: 2024-03-20 to 2024-05-20 |
| V1.1.1 | May 2024 | Publication | |
| | | | |
| | | | |